ZOOMLION

ZOOMLION ZLJ5880JQZ800H ALL TERRAIN CRANE

TECHNICAL SPECIFICATIONS

ZAT8000H753/27Y

Zoomlion Heavy Industry Science & Technology Co.,Ltd.

ZOOMLION ZLJ5880JQZ800H ALL TERRAIN CRANE

TECHNICAL SPECIFICATIONS

ZAT8000H753/27Y

Specifications, complete vehicle

Product model

Model in auto industry: ZLJ5880JQZ800H

Model in engineering industry: ZAT8000H

Code: ZAT8000H753

Product appearance

Main boom: 92m Wind plant tip boom: 33m Counterweight: 195t



Technical data

Table 1 Technical data

Item		Value	Remarks	
Work performance	Max. rated lifting capacity		800	
	Max. load moment of basic boom	t.m	2160	
	Max. load moment of main boom (fully extended)	t.m	1650	
	Max. lifting height of basic boom	m	21.6	
	Max. lifting height of main boom	m	95.8	
	Max. lifting height of wind plant tip boom	m	128.8	
Work speeds	Max. hoist rope speed (Main winch)	m/min	120	
	Boom derricking up time	s	135	
	Boom derricking up time (7 sections)	s	1300	
	Slewing speed	r/min	0 - 0.8	
Driving	Max. operation altitude	m	2000	
	Max. driving speed	km/h	80	
	Max. gradeability	%	63.5	
	Min. turning diameter	m	≤27.7	
	Min. ground clearance	mm	335	
	Limits for exhaust pollutants and smoke		National stage V	
	Front overhang angle	°	14	
	Rear overhang angle	°	19	
Mass	Deadweight in driving condition	kg	88000	
	Complete vehicle kerb mass	kg	87805	
	Single axle load	kg	12000	
Dimensions	Overall dimensions (L×W×H)	mm	19979×3000×4000	
	Outrigger spread (W)	m	12	
	Outrigger spread (L)	m	12	
	Slewing radius of counterweight tail	mm	7960	
	Main boom length (7 sections)	mm	17.8-92	
	Main boom length (4 sections)	m	20.1 - 57.7	Including 3m head section
	Boom angle	°	-0.4 - 86	
	Length of wind plant tip boom	m	21, 27, 33	
Others	Superlift device		Y-shaped single piece superlift	
	Telescoping mode of main boom		Single cylinder telescoping system with double side pins	
	Derricking mode		Double-cylinder	

Table of options

Table 2 Options

No.	Description	Remarks
1	3m head section	Used with 4-section main boom together
2	Counterweight	Standard configuration: 135t Optional: 60t Total (full configuration): 195t
3	Hook	Standard configuration: 110t Optional: 350t, 260t, 180t, 50t, 27t, 12t

Dimensions (unit: mm)

Bulletin condition: complete vehicle without main boom and rear outriggers

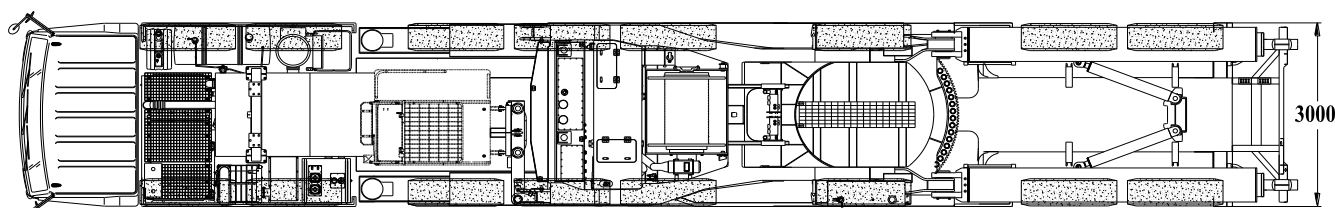
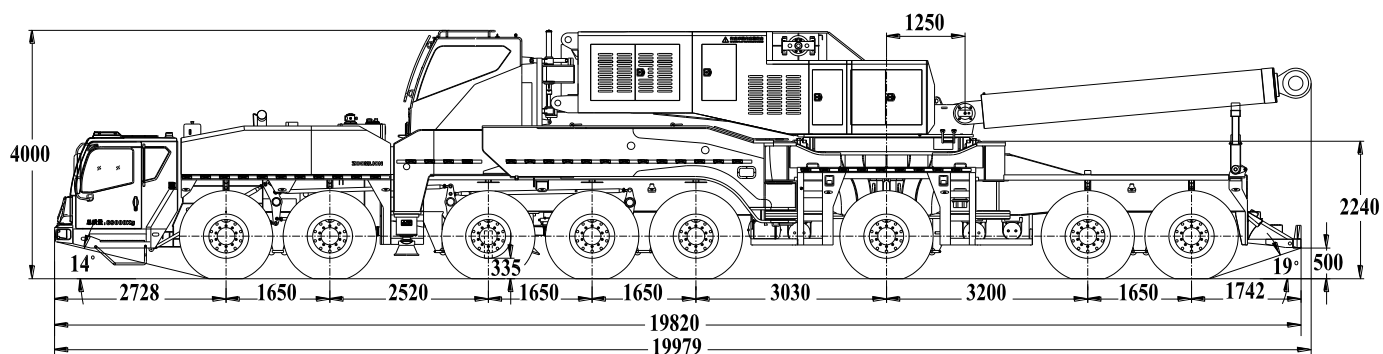

Operation condition

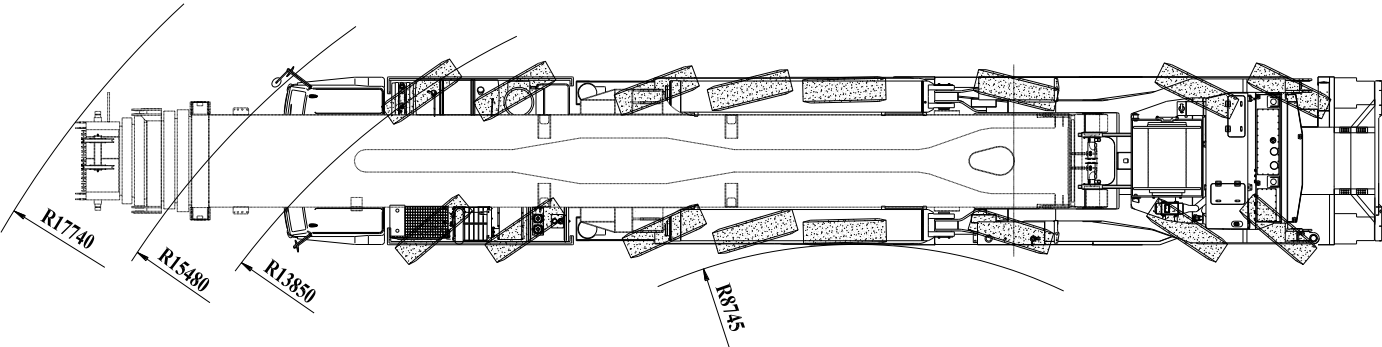
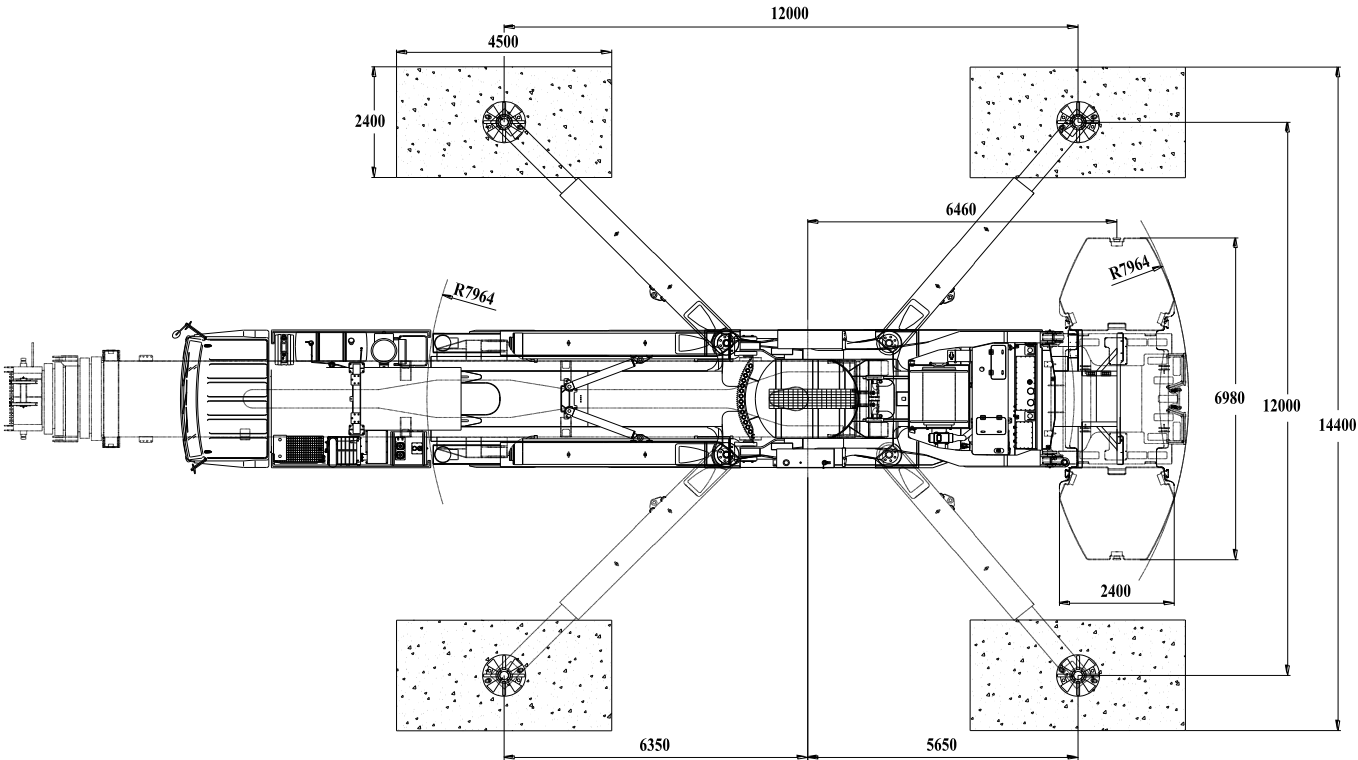
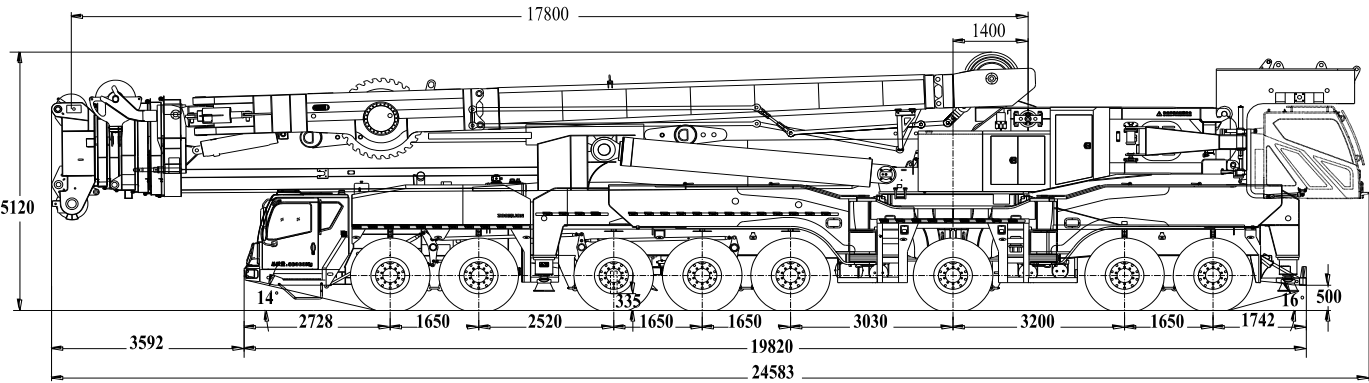

Dimensions, travelling (unit: mm)

① High speed mode (H): complete vehicle without main boom and rear outriggers

For long distance travelling and vehicle speed below 80 km/h

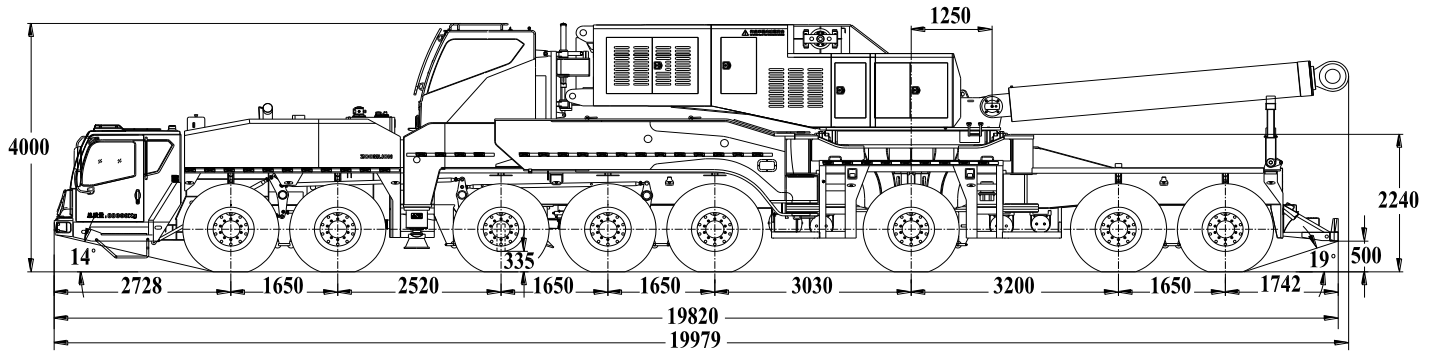

② City mode (C): complete vehicle without main boom and with rear outriggers

For long distance travelling and vehicle speed below 60 km/h

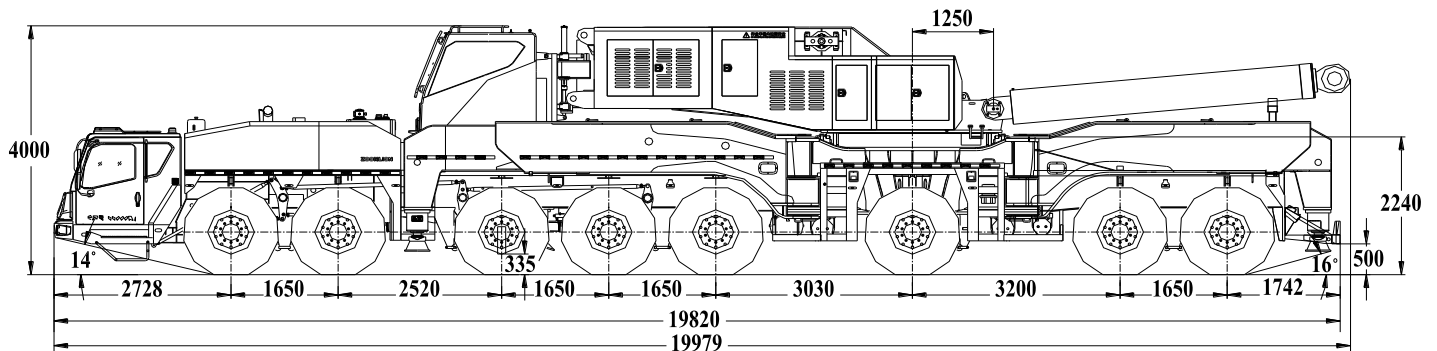

③ Half of boom mode (T): complete vehicle with 2-section boom and rear outriggers

For short distance travelling and vehicle speed below 30 km/h

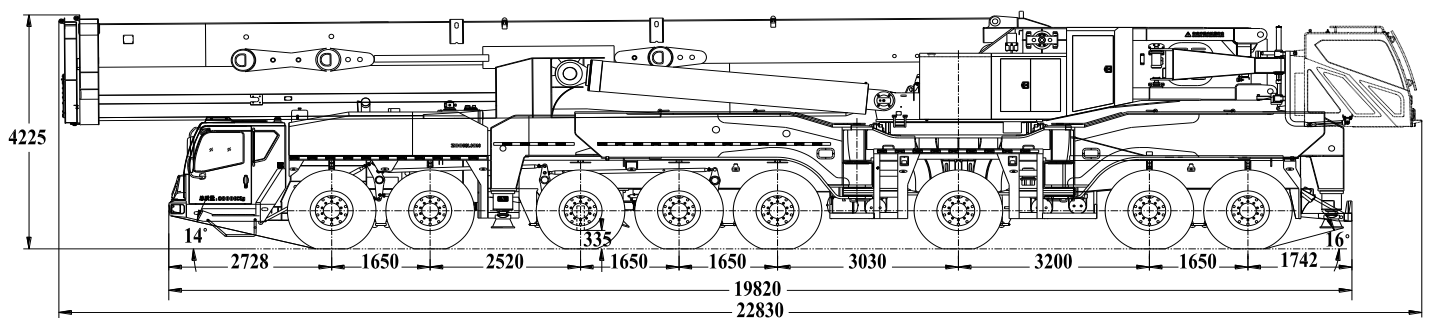

④ Half of boom mode (T): complete vehicle with 4-section boom and rear outriggers

For short distance travelling and vehicle speed below 30 km/h

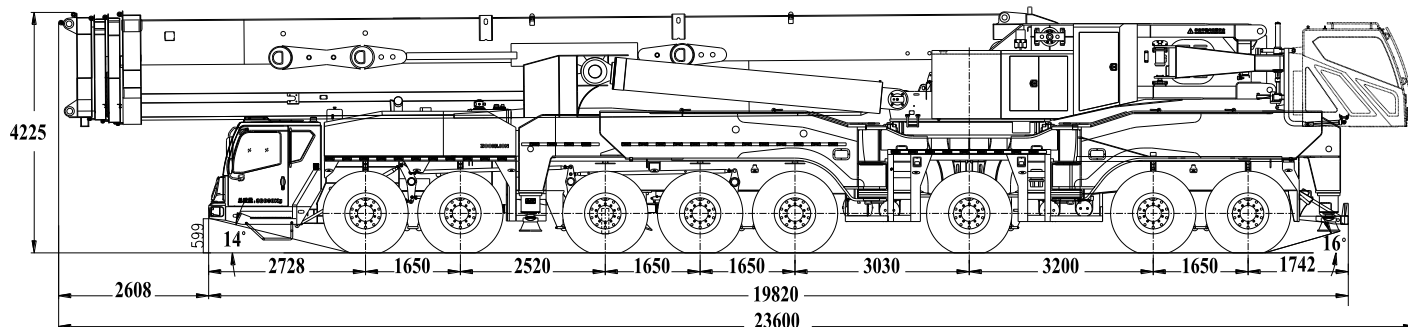

⑤ All boom mode (G): complete vehicle with 7-section boom and rear outriggers

For short distance travelling and vehicle speed below 5 km/h

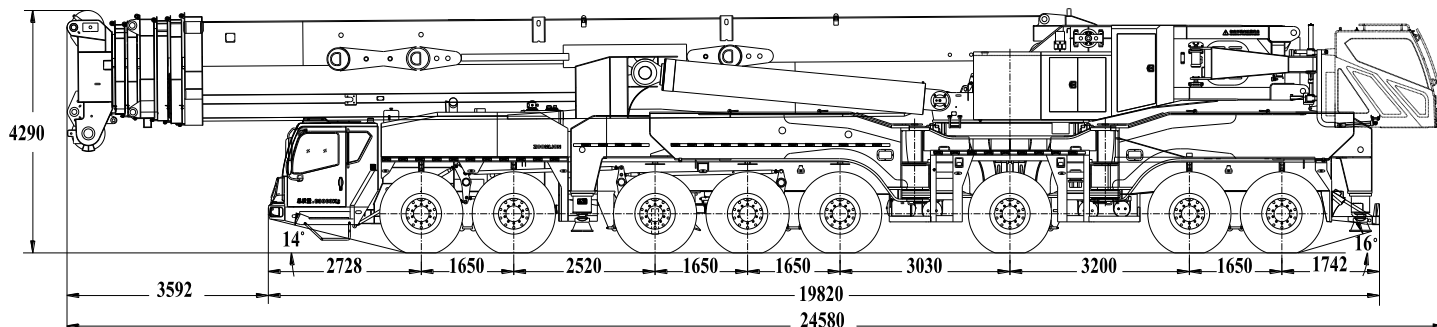

⑥ All boom mode (G): complete vehicle with 7-section boom, superlift device, counterweight carrier and rear outriggers

For short distance travelling and vehicle speed below 5 km/h

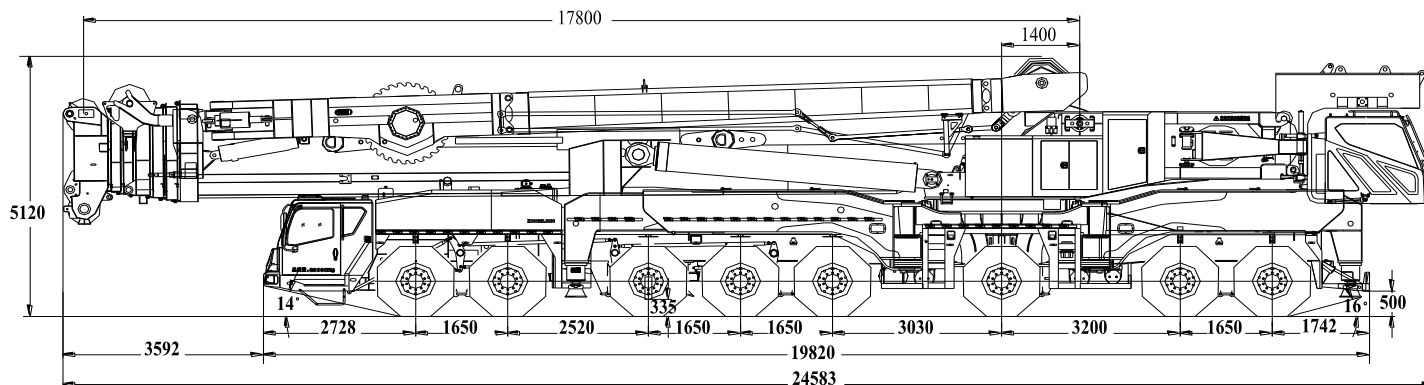

Weight in travelling order (Unit: t)

Table 3 Weight distribution in travelling order

	1	2	3	4	5	6	7	8	Total weight (t)
①	10.4	10.4	10.4	10.4	10.4	12	12	12	88
②	12	12	12	12	12	13	13	13	99
③	16	16	16	16	16	15.3	15.3	15.3	126
④	18	18	18	18	18	17	17	17	141
⑤	20	20	20	20	20	19.7	19.7	19.7	159
⑥	25	25	25	25	25	23	23	23	194

Hook

Table 4 Hook

Specification	Weight (t)	Transport dimensions (mm)	Reeving	Single/double hook	Standard/ optional configuration
350t	6.1	3110×1715×760	33	Double	Optional
260t	4.2	2420×1412×860	27	Double	Optional
180t	3.3	2280×950×860	17	Double	Optional
110t	3	2080×700×860	9	Double	Standard
50t	1.9	1760×560×860	5	Single	Optional
27t	1.4	1840×400×860	3	Single	Optional
12t	0.7	1100×450×450	1	Single	Optional

Wire rope

Table 5 Wire rope

	Diameter (mm)	Length (m)	Max. permissible lifting capacity of single wire rope (t)
Main hoist rope	φ25	950	14.5

Counterweight

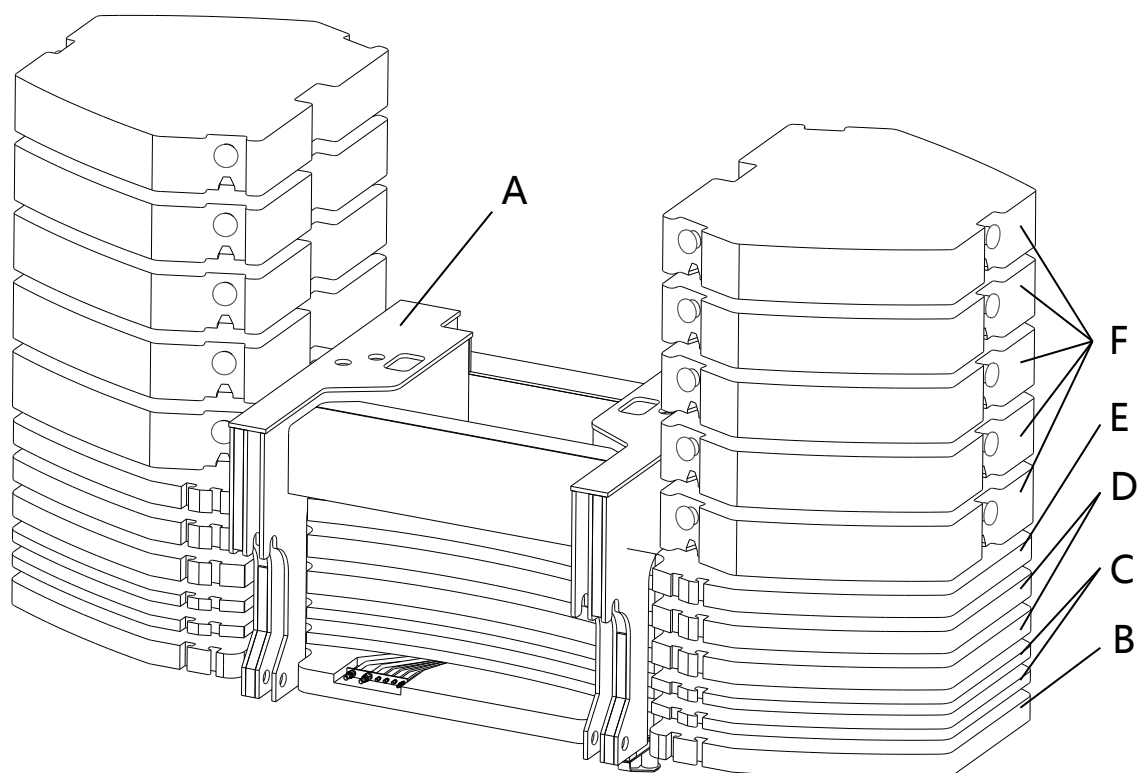

Table 6 Counterweight

	A	B	C	D	E	F
Weight (t)	12	23	7.5	15	15	10
Transport dimensions (m)	3×2.8×2.5	7×2.4×1.6	7×2.4×0.15	7×2.4×0.26	7×2.4×0.3	2×2.4×0.52
Quantity of full configuration (piece)	1	1	2	2	1	10

Table 7 Counterweight combinations (Unit: piece)

Combinations	A	B	C	D	E	F
0t	0	0	0	0	0	0
50t	1	1	2	0	0	0
80t	1	1	2	2	0	0
95t	1	1	2	2	1	0
115t	1	1	2	2	1	2
135t	1	1	2	2	1	4
155t	1	1	2	2	1	6
195t	1	1	2	2	1	10

Dismantle transport componants

Booms 85 and 86: 32t

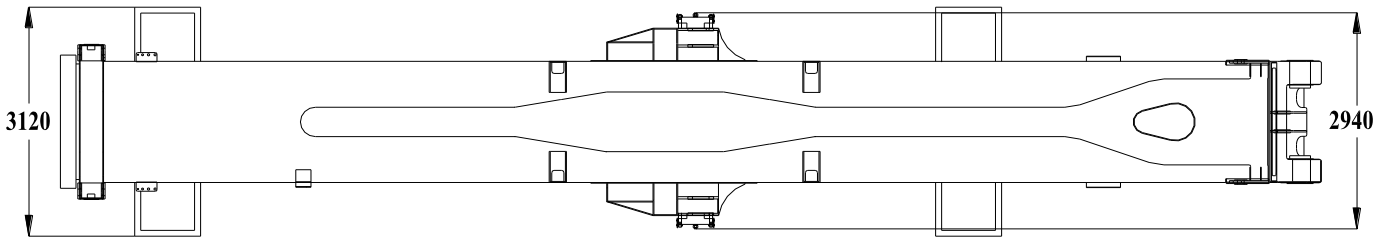
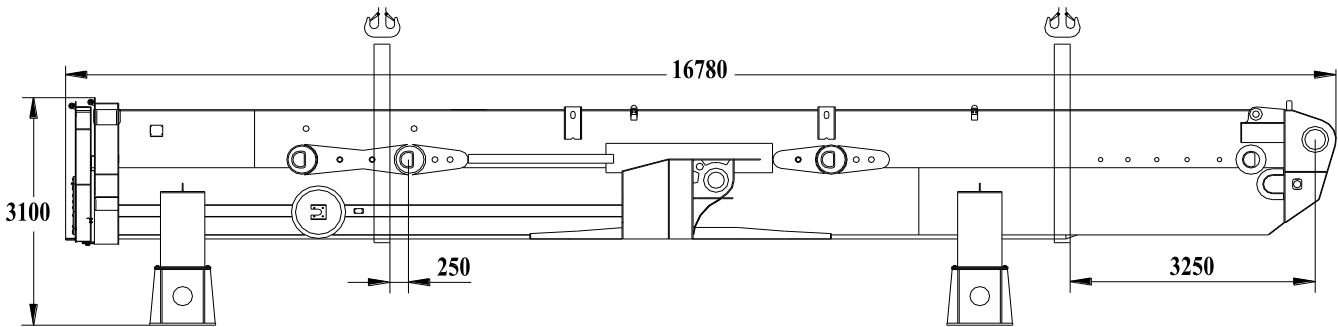

Booms 87 and 88: 16t

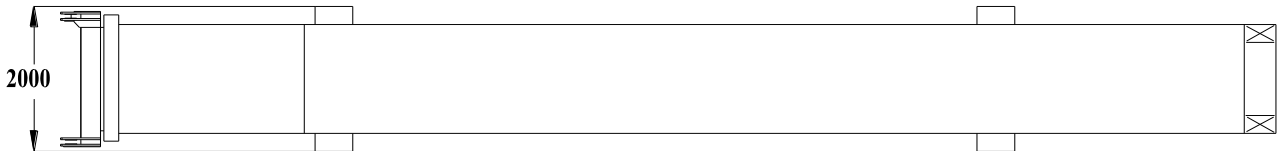
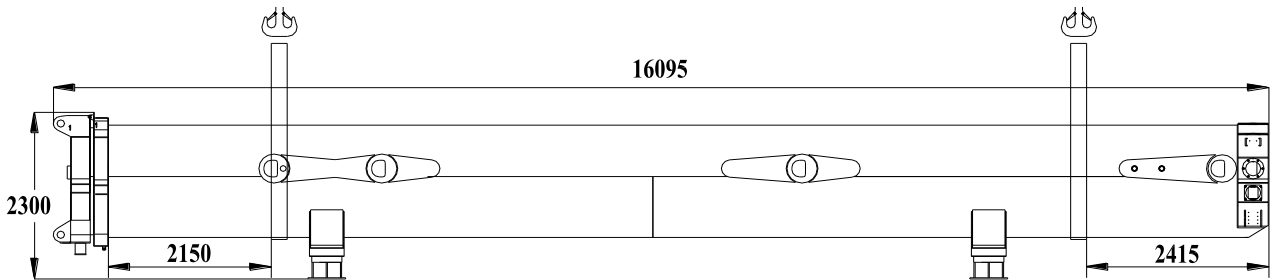

Booms 89, 90 and 95: 18.7t

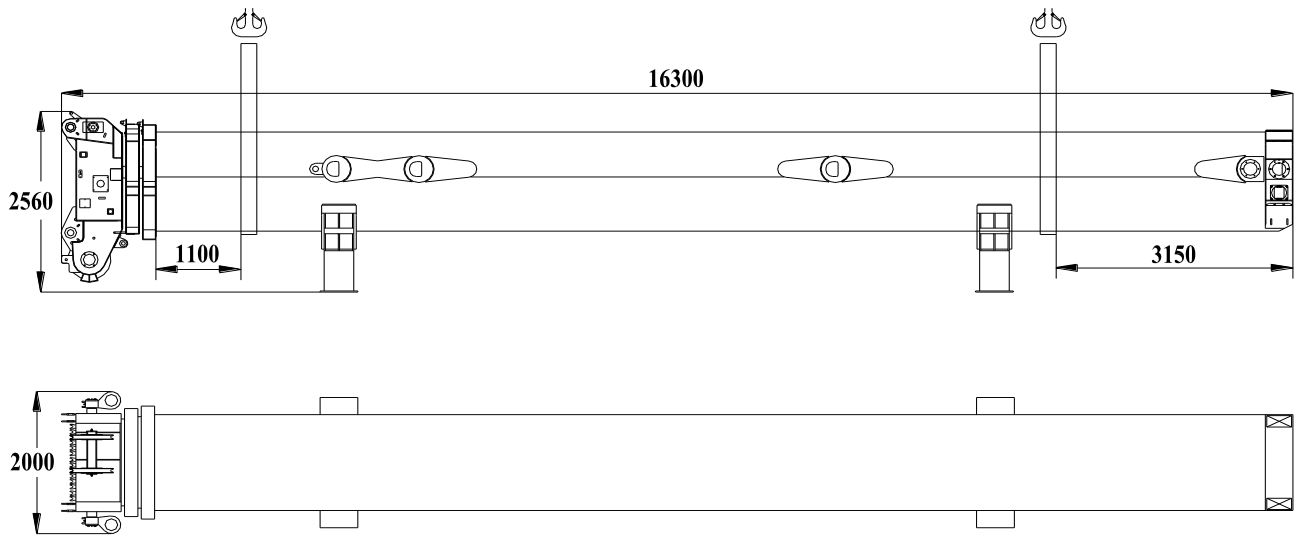

Superlift: 21t

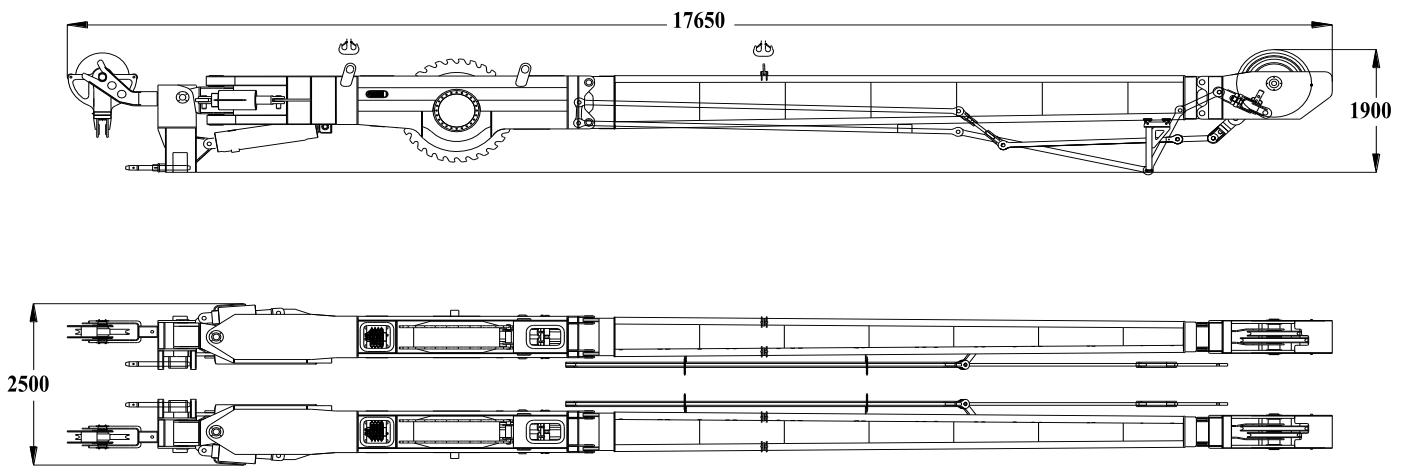

Wind plant tip boom: 5.6t

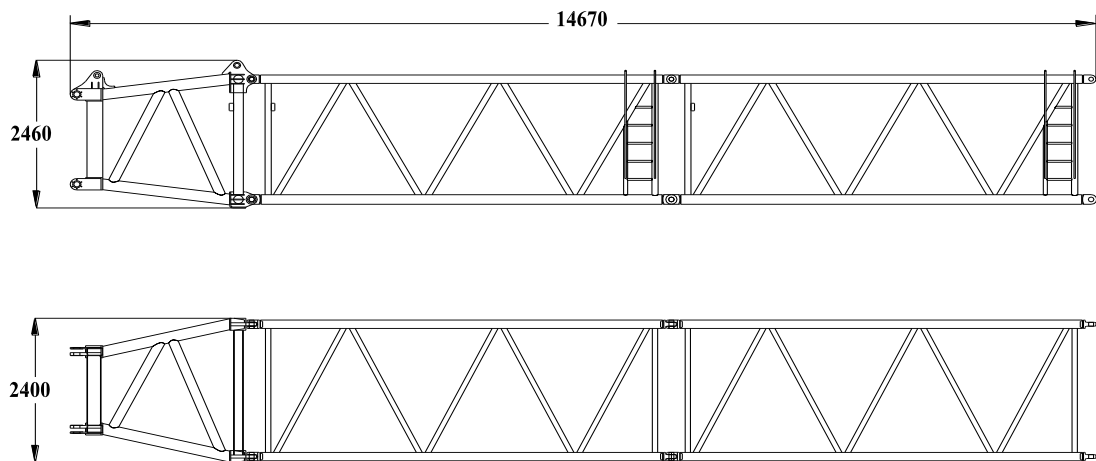

Wind plant tip boom: 5.7t

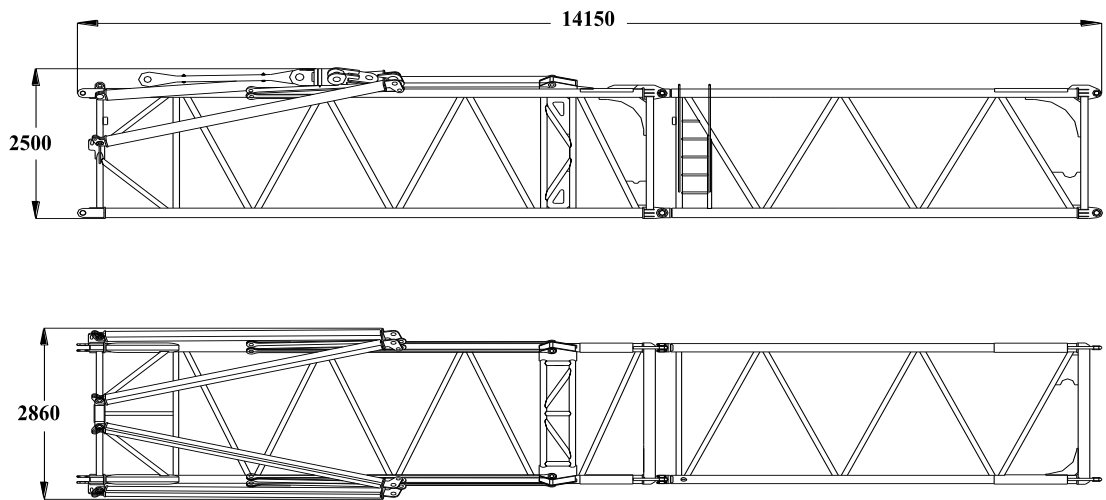

Tip boom: 2.3t

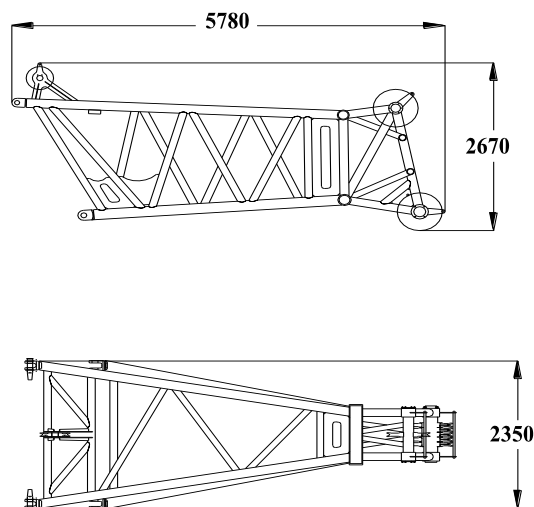

Rear outrigger: 5.3t

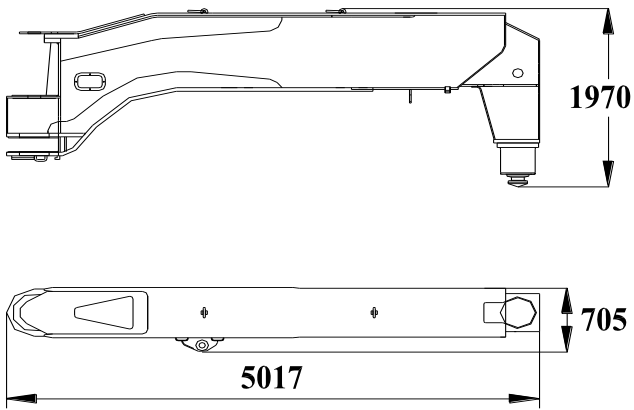

Outrigger pad: 2.5t

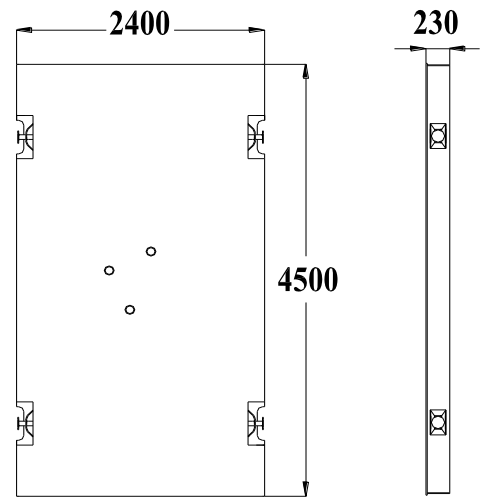

Counterweight carrier: 1t

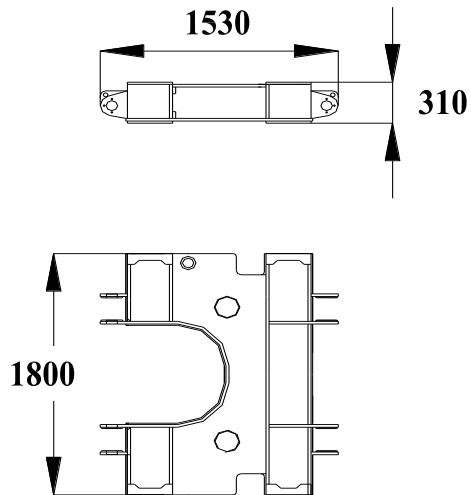

Outrigger pad: 160kg

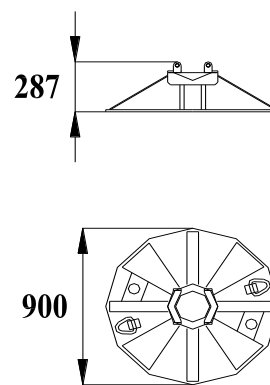

OM combinations

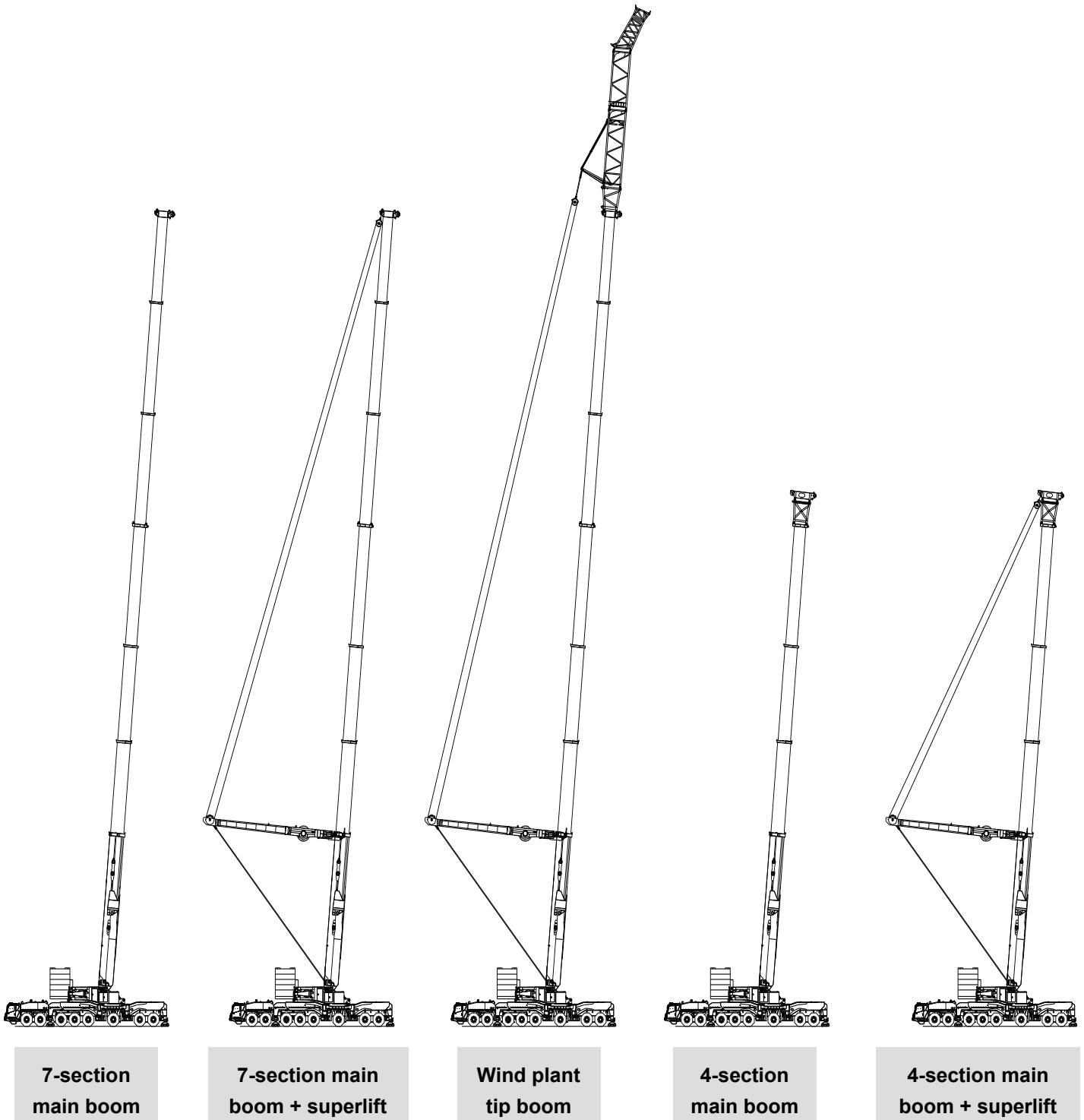

Lifting capacity tables / Lifting height charts

7-section main boom OM: 17.8m – 92m

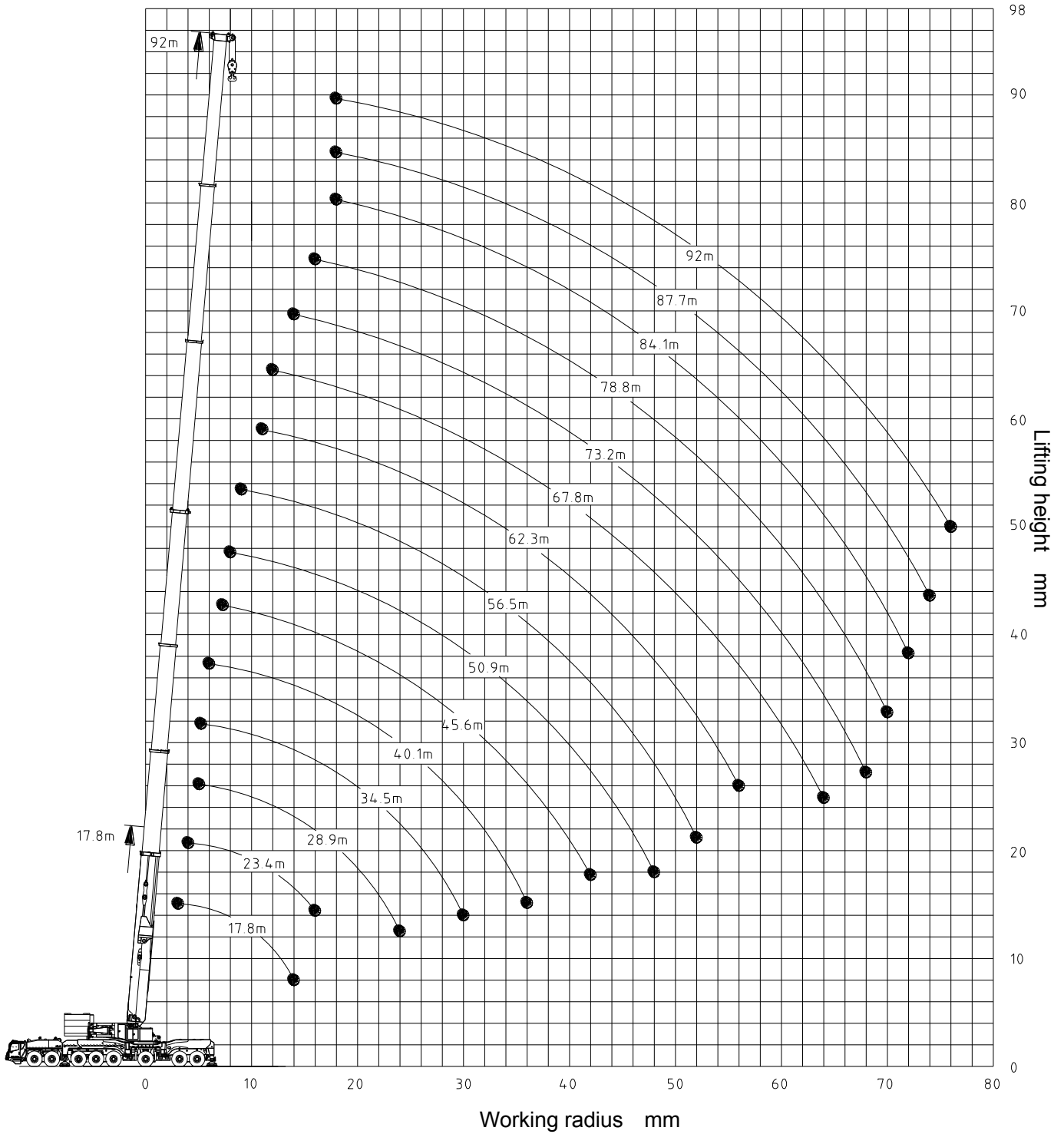



Table 8-1 Main boom (7 sections) 

Unit: t

Main boom 17.8m – 92m, outrigger fully extended (12m x 12m), over full range, 155t counterweight														
Radius (m)	Main boom (m)												Radius (m)	
	17.8	23.4	23.4	23.4★	28.9	28.9	28.9★	34.2	34.5	34.5★	39.8	40		
3	800*												3	
3.5	250												3.5	
4	245	245	240	245									4	
4.5	245	245	235	245	210	245	240						4.5	
5	235	235	230	235	205	240	235	128	220	235			5	
5.5	230	230	220	230	200	235	230	123	220	230			5.5	
6	225	225	210	225	188	230	225	117	210	225	128	175	6	
7	220	220	205	220	168	225	215	112	192	215	120	160	7	
8	215	215	200	215	151	215	200	107	172	200	114	147	8	
9	208	205	188	205	138	205	184	102	154	190	107	132	9	
10	198	190	176	195	125	192	168	98	142	180	101	122	10	
11	178	172	164	175	114	176	155	91	131	170	94	115	11	
12	165	158	147	164	108	164	142	86	120	155	85	107	12	
14	146	132	128	138	94	142	126	76	104	135	72	95	14	
16		115	112	120	80	120	108	68	94	121	63	82	16	
18					71	106	97	60	80	98	54	73	18	
20					62	89	86	54	71	88	48	64	20	
22					57	77	76	48	63	80	42	56	22	
24					46	67	67	44	58	70	38	50	24	
26								37	50	62	35	45	26	
28								33	51	55	32	40	28	
30								29	46	48	29	36	30	
32											25	32	32	
34											23	29	34	
36											22	27	36	
38													38	
Reeving	22	22	22	22	18	22	22	10	20	20	12	16	Reeving	
Wind speed	14.1m/s				12.8m/s				11.1m/s				Wind speed	
Hook	260t (deadweight 4.2t)												Hook	
Telescoping mode	I	1	2	1	1	1	2	1	1	1	2	1	1	I
	II	1	1	1	2	1	2	2	1	2	2	1	2	II
	III	1	1	2	1	2	1	2	1	2	2	2	2	III
	IV	1	1	1	1	2	1	1	2	2	1	2	2	IV
	V	1	1	1	1	1	1	1	2	1	1	2	2	V
	VI	1	1	1	1	1	1	1	2	1	1	2	1	VI

Note:

1. OM marked with the asterisk (*) is a nominal one.
2. The telescoping modes marked with the pentacle (★) are optimal ones.

Table 8-2 Main boom (7 sections)



Unit: t

Main boom 17.8m – 92m, outrigger fully extended (12m x 12m), over full range, 155t counterweight														
Radius (m)	Main boom (m)												Radius (m)	
	40.1★	45.1	45.4	45.6★	50.7	51.1	50.9★	56.2	56.5	56.5★	61.8	62.1		
6	200												6	
7	190	86	130	175									7	
8	175	81	124	165	85	115	125						8	
9	160	75	118	153	80	110	124	55	92	92			9	
10	150	70	112	142	76	103	118	50	90	90			10	
11	135	65	106	136	72	95	114	48	82	85	56	72	11	
12	130	60	99	128	68	87	110	43	78	82	52	68	12	
14	110	54	86	110	62	76	98	40	70	74	48	61	14	
16	100	48	77	100	55	66	90	36	62	65	42	54	16	
18	86	42	68	88	50	58	80	32	56	60	38	49	18	
20	75	40	60	79	46	51	72	28	52	54	34	46	20	
22	70	36	55	70	42	46	66	25	48	50	31	40	22	
24	65	34	49	65	39	42	60	23	44	46	28	37	24	
26	57	32	46	60	37	38	56	20	37	41	25	34	26	
28	52	30	42	55	35	35	50	18	35	38	23	32	28	
30	48	27	39	50	32	32	47	17	32	35	21	30	30	
32	45	25	37	46	30	29	44	16	29	31.5	20	27	32	
34	40	23	34	41	28	28	40	15	27	29.5	19	25.8	34	
36	36	20	32	37	27	24	37	13	25	27	17	24	36	
38		18	30	34	25	21	35	12	23	25	16	21.5	38	
40		17	28	32	23	20	32	11	21	23	15	20	40	
42		16	25	28	21	19	29	10	19	21.5	14	18	42	
44					20	17	26	9	17	19	13	16	44	
46					19	16	23	8	15	17.8	12	15	46	
48					18	15	20	7	14	16	11	14	48	
50								6	13	14	10	13	50	
52								5.5	12	13	9	11.5	52	
54											8	10.5	54	
56											7.5	9	56	
58													58	
Reeving	18	8	12	16	8	10	12	6	8	8	6	6	Reeving	
Wind speed	11.1m/s												Wind speed	
Hook	260t	180t (deadweight 3.3t)						110t (deadweight 3t)						Hook
Telescoping mode	I	2	1	1	2	1	3	2	1	2	3	1	2	I
	II	2	1	2	2	2	2	2	1	3	2	2	3	II
	III	2	2	2	2	2	2	2	2	2	2	2	3	III
	IV	2	2	2	2	2	2	2	3	2	2	3	2	IV
	V	1	2	2	2	2	2	2	3	2	2	3	2	V
	VI	1	3	2	1	3	1	2	3	2	2	3	2	VI

Table 8-3 Main boom (7 sections) 

Unit: t

Main boom 17.8m – 92m, outrigger fully extended (12m x 12m), over full range, 155t counterweight															
Radius (m)	Main boom (m)													Radius (m)	
	62.3★	67.4	67.6	67.8★	72.9	73.1	73.2★	78.5	78.5	78.8★	84.1★	87.7★	92★		
11	75													11	
12	70	50	62	62										12	
14	66	42	55	60	49	52	52							14	
16	58	38	50	55	42	48	50	42	42	42				16	
18	52	35	46	50	36	42	46	38	40	40	37	32	32	18	
20	48	32	42	46	30	37	42	34	36	38	34	30	30	20	
22	43	29	38	41	29	35	40	31	34	36	31	27	27	22	
24	39	26	36	38	26	31	35	29	32	34	29	26	25	24	
26	35	24	32	34	25	30	33	27	30	31	27	23	23	26	
28	32	22	30	31	24	27	30	26	28	28	25	21	21	28	
30	29.5	20	28	29	22	25	27	23	26	26	23	20	20	30	
32	27.5	19	26	26.5	21	23	25	22	25	24	21	18	18	32	
34	25.4	18	24	24	20	22	24	20	23	22	20	17	17	34	
36	23.5	17	22.5	22.8	19	20	21.5	18	21	20	18	16	16	36	
38	21	15.5	20.5	21	18	19	20	17	20	19	17	15	15	38	
40	19	14	19	19.4	17	18	18.5	16	19	18	15	14	14	40	
42	17.4	13	18	18	15	16	17	15	18	16	14	13	13	42	
44	15.5	12	16	16	14.5	15.5	15.5	14	16	15	14	12	12	44	
46	14	11	14.8	14.5	14	14	14	13	15	13.5	13	11	11	46	
48	13	10.5	13	12.7	12.5	12.5	12.5	12	13.5	12.5	11	10	10	48	
50	12	10	12	11.5	11.5	11.5	11.5	11	13	12	10	9.6	10	50	
52	10.8	9.5	11	10	11	11	11	10.2	12	11	9.5	9	9.3	52	
54	9.7	8.5	10	9.2	10	10	10	10	11	10	9	8.5	8.7	54	
56	8	8	9.2	8.3	10	9.5	9	9	10.5	9.5	8.4	8	8	56	
58		7	8	7	9	8.5	8	8	10	8.6	7.6	7	7	58	
60		6	7	6	8	7	7	7.5	9	8	7	6.5	6.7	60	
62		5	6	5	7	6.5	6.2	7	8	6.8	6.5	6	6.2	62	
64		4	5	4	6.5	6	5.5	6.5	7.5	6	6	5.6	5.8	64	
66					6	5	4.5	6	7	5	5.4	5.5	5.5	66	
68					5	4	3.2	5	5.5	4	5	5	5	68	
70								4	4.5	3.5	4.4	4.6	4.8	70	
72											4	4.2	4.4	72	
74												4	4	74	
76													3.5	76	
Reeving	6	6	6	6	4	4	4	4	4	4	4	4	4	Reeving	
Wind speed	9m/s													Wind speed	
Hook	110t (deadweight 3t)					50t (deadweight 1.9t)								Hook	
Telescoping mode	I	3	1	2	3	2	2	3	2	3	3	3	3	4	I
	II	3	2	3	3	2	3	3	3	2	3	3	3	4	II
	III	3	3	3	3	3	3	3	3	3	3	3	3	4	III
	IV	2	3	3	3	3	3	3	3	3	3	3	4	4	IV
	V	2	3	2	2	3	3	2	3	3	3	3	4	4	V
	VI	1	3	2	1	3	2	2	3	3	2	3	4	4	VI

Table 9-1 Main boom (7 sections) 

Unit: t

Main boom 17.8m – 92m, outrigger fully extended (12m x 12m), over full range, 135t counterweight														
Radius (m)	Main boom (m)												Radius (m)	
	17.8	23.4	23.4	23.4★	28.9	28.9	28.9★	34.2	34.5	34.5★	39.8	40		
3.5	250												3.5	
4	245	245	240	245									4	
4.5	245	245	235	245	210	245	240						4.5	
5	235	235	230	235	205	240	235	128	220	235			5	
5.5	230	230	220	230	200	235	230	123	220	230			5.5	
6	225	225	210	225	188	230	225	117	210	225	128	175	6	
7	220	220	205	220	168	225	215	112	192	215	120	160	7	
8	215	215	200	215	151	215	200	107	172	200	114	147	8	
9	208	200	188	202	138	202	184	102	154	190	107	132	9	
10	192	188	176	180	125	188	168	98	142	180	101	122	10	
11	176	170	162	172	114	173	155	91	131	170	94	115	11	
12	163	156	146	161	108	162	142	86	120	155	85	107	12	
14	136	127	124	134	94	133	126	76	104	132	72	95	14	
16		105	100	112	80	110	104	68	94	110	63	82	16	
18					71	94	87	60	80	92	54	73	18	
20					62	78	78	54	71	79	48	64	20	
22					57	68	68	48	61	69	42	56	22	
24					46	58	58	44	54	59	38	50	24	
26								37	49	52	35	45	26	
28								33	45	45	32	40	28	
30								29	41	40	29	36	30	
32											25	32	32	
34											23	29	34	
36											22	26	36	
Reeving	22	22	22	22	18	22	22	10	20	20	12	16	Reeving	
Wind speed	14.1m/s				12.8m/s			11.1m/s					Wind speed	
Hook	260t (deadweight 4.2t)												Hook	
Telescoping mode	I	1	2	1	1	1	2	1	1	1	2	1	1	I
	II	1	1	1	2	1	2	2	1	2	2	1	2	II
	III	1	1	2	1	2	1	2	1	2	2	2	2	III
	IV	1	1	1	1	2	1	1	2	2	1	2	2	IV
	V	1	1	1	1	1	1	1	2	1	1	2	2	V
	VI	1	1	1	1	1	1	1	2	1	1	2	1	VI

Table 9-2 Main boom (7 sections) 

Unit: t

Main boom 17.8m – 92m, outrigger fully extended (12m x 12m), over full range, 135t counterweight														
Radius (m)	Main boom (m)												Radius (m)	
	40.1★	45.1	45.4	45.6★	50.7	51.1	50.9★	56.2	56.5	56.5★	61.8	62.1		
6	200												6	
7	190	86	130	175									7	
8	175	81	124	165	85	115	125						8	
9	160	75	118	153	80	110	124	55	92	92			9	
10	150	70	112	142	76	103	118	50	90	90			10	
11	135	65	106	136	72	95	114	48	82	85	56	72	11	
12	130	60	99	128	68	87	110	43	78	82	52	68	12	
14	110	54	86	110	62	76	98	40	70	74	48	61	14	
16	100	48	77	100	55	66	90	36	62	65	42	54	16	
18	86	42	68	88	50	58	80	32	56	60	38	49	18	
20	73	40	60	76	46	51	72	28	52	54	34	46	20	
22	65	36	55	67	42	46	66	25	48	50	31	40	22	
24	59	34	49	60	39	42	59	23	44	46	28	37	24	
26	42	32	46	53	37	38	54	20	37	41	25	34	26	
28	46	30	41	48	35	35	47	18	35	38	23	32	28	
30	41	27	38	43	32	32	44	17	32	35	21	30	30	
32	37	25	36	40	30	29	40	16	29	31	20	27	32	
34	33	23	32	35	28	28	36	15	27	29	19	25.2	34	
36	29	20	29	32	27	24	32	13	25	27	17	24	36	
38		18	27	29	25	21	30	12	23	24	16	21	38	
40		17	25	27	23	20	27	11	21	22	15	20	40	
42		16	22	24	21	18	24	10	19	20	14	18	42	
44					19	16	21	9	17	18	13	16	44	
46					18	14	19	8	15	16	12	15	46	
48					17	13	16	7	14	15	11	14	48	
50								6	13	12	10	13	50	
52								5.5	11	12	9	11	52	
54											8	10	54	
56											7.5	8	56	
58													58	
Reeving	18	8	12	16	8	10	12	6	8	8	6	6	Reeving	
Wind speed	11.1m/s												Wind speed	
Hook	260t	180t (deadweight 3.3t)						110t (deadweight 3t)						Hook
Telescoping mode	I	2	1	1	2	1	3	2	1	2	3	1	2	I
	II	2	1	2	2	2	2	2	1	3	2	2	3	II
	III	2	2	2	2	2	2	2	2	2	2	2	3	III
	IV	2	2	2	2	2	2	2	3	2	2	3	2	IV
	V	1	2	2	2	2	2	2	3	2	2	3	2	V
	VI	1	3	2	1	3	1	2	3	2	2	3	2	VI

Table 9-3 Main boom (7 sections)



Unit: t

Main boom 17.8m – 92m, outrigger fully extended (12m x 12m), over full range, 135t counterweight																
Radius (m)	Main boom (m)													Radius (m)		
	62.3★	67.4	67.6	67.8★	72.9	73.1	73.2★	78.5	78.5	78.8★	84.1★	87.7★	92★			
11	75													11		
12	70	50	62	62										12		
14	66	42	55	60	49	52	52							14		
16	58	38	50	55	42	48	50	42	42	42				16		
18	52	35	46	50	36	42	46	38	40	40	37	32	32	18		
20	48	32	42	46	30	37	42	34	36	38	34	30	30	20		
22	43	29	38	41	29	35	40	31	34	36	31	27	27	22		
24	39	26	36	38	26	31	35	29	32	34	29	26	25	24		
26	35	24	32	34	25	30	33	27	30	31	27	23	23	26		
28	32	22	30	31	24	27	30	26	28	28	25	21	21	28		
30	29	20	28	29	22	25	27	23	26	26	23	20	20	30		
32	27	19	26	26	21	23	25	22	25	24	21	18	18	32		
34	25	18	24	24	20	22	24	20	23	22	20	17	17	34		
36	23	17	22	22.5	19	20	21.5	18	21	20	18	16	16	36		
38	21	15.5	20	21	18	19	20	17	20	19	17	15	15	38		
40	19	14	19	19	17	18	18.5	16	19	18	15	14	14	40		
42	17.4	13	18	18	15	16	17	15	18	16	14	13	13	42		
44	15.5	12	16	16	14	5	15	14	16	15	14	12	12	44		
46	14	11	14	14	14	14	14	13	15	13	13	11	11	46		
48	13	10	13	12.5	12	12	12	12	13	12	11	10	10	48		
50	12	10	12	11	11	11	11	11	13	12	10	9.6	10	50		
52	10	9	11	10	11	11	11	10	12	11	9.5	9	9.3	52		
54	9	8	10	9	10	10	10	10	11	10	9	8.2	8.5	54		
56	8	8	9	8	10	8	9	9	10	9	8.4	8	8	56		
58		7	8	7	9	7	8	8	9.5	8.3	7.6	7	7	58		
60		6	7	6	8	7	7	7	9	7.5	7	6.5	6.7	60		
62		5	6	4.5	7	5	6	6.5	8	6.4	6.5	6	6.2	62		
64		4	5	3.5	6.5	6	5	6	7.5	6	6	5.6	5.8	64		
66					6	5	4	6	7	5	5.4	5	5.5	66		
68					5	4	3	5	5	4	5	5	5	68		
70								4	4	3	4	4.3	4.4	70		
72											3.5	3.2	4	72		
74												3.5	3.5	74		
Reeving	6	6	6	6	4	4	4	4	4	4	4	4	4	Reeving		
Wind speed	9m/s													Wind speed		
Hook	110t (deadweight 3t)						50t (deadweight 1.9t)						Hook			
Telescoping mode	I	3	1	2	3	2	2	3	2	3	3	3	3	4	I	Telescoping mode
	II	3	2	3	3	2	3	3	3	2	3	3	3	4	II	
	III	3	3	3	3	3	3	3	3	3	3	3	3	4	III	
	IV	2	3	3	3	3	3	3	3	3	3	3	4	4	IV	
	V	2	3	2	2	3	3	2	3	3	3	3	4	4	V	
	VI	1	3	2	1	3	2	2	3	3	2	3	4	4	VI	

Table 10-1 Main boom (7 sections) 

Unit: t

Main boom 17.8m – 92m, outrigger fully extended (12m x 12m), over full range, 115t counterweight														
Radius (m)	Main boom (m)												Radius (m)	
	17.8	23.4	23.4	23.4★	28.9	28.9	28.9★	34.2	34.5	34.5★	39.8	40		
3.5	250												3.5	
4	245	245	240	245									4	
4.5	245	245	235	245	210	245	240						4.5	
5	235	235	230	235	205	240	235	128	220	235			5	
5.5	230	230	220	230	200	235	230	123	220	230			5.5	
6	225	225	210	225	188	230	225	117	210	225	128	175	6	
7	220	220	205	220	168	225	215	112	192	215	120	160	7	
8	215	215	200	215	151	215	200	107	172	200	114	147	8	
9	205	200	188	202	138	200	184	102	154	190	107	132	9	
10	190	188	176	189	125	185	168	98	142	180	101	122	10	
11	175	170	162	172	114	171	155	91	131	167	94	115	11	
12	162	155	145	162	108	160	142	86	120	155	85	107	12	
14	126	124	120	130	94	126	126	76	104	129	72	95	14	
16		98	92	104	80	100	97	68	94	102	63	82	16	
18					71	82	78	60	80	85	54	73	18	
20					62	70	71	54	71	71	48	64	20	
22					57	60	62	48	60	60	42	56	22	
24					46	50	52	44	52	51	38	50	24	
26								37	45	44	35	45	26	
28								33	40	38	32	40	28	
30								29	34	33	29	36	30	
32											25	32	32	
34											23	28	34	
36											22	25	36	
Reeving	22	22	22	22	18	22	22	10	20	20	12	16	Reeving	
Wind speed	14.1m/s				12.8m/s				11.1m/s				Wind speed	
Hook	260t (deadweight 4.2t)												Hook	
Telescoping mode	I	1	2	1	1	1	2	1	1	1	2	1	1	I
	II	1	1	1	2	1	2	2	1	2	2	1	2	II
	III	1	1	2	1	2	1	2	1	2	2	2	2	III
	IV	1	1	1	1	2	1	1	2	2	1	2	2	IV
	V	1	1	1	1	1	1	1	2	1	1	2	2	V
	VI	1	1	1	1	1	1	1	2	1	1	2	1	VI

Table 10-2 Main boom (7 sections) 

Unit: t

Main boom 17.8m – 92m, outrigger fully extended (12m x 12m), over full range, 115t counterweight														
Radius (m)	Main boom (m)												Radius (m)	
	40.1★	45.1	45.4	45.6★	50.7	51.1	50.9★	56.2	56.5	56.5★	61.8	62.1		
6	200												6	
7	190	86	130	175									7	
8	175	81	124	165	85	115	125						8	
9	160	75	118	153	80	110	124	55	92	92			9	
10	150	70	112	142	76	103	118	50	90	90			10	
11	135	65	106	136	72	95	114	48	82	85	56	72	11	
12	130	60	99	128	68	87	110	43	78	82	52	68	12	
14	110	54	86	110	62	76	98	40	70	74	48	61	14	
16	100	48	77	100	55	66	90	36	62	65	42	54	16	
18	86	42	68	88	50	58	80	32	56	60	38	49	18	
20	72	40	60	75	46	51	72	28	52	54	34	46	20	
22	61	36	55	64	42	46	66	25	48	50	31	40	22	
24	53	34	49	55	39	42	58	23	44	46	28	37	24	
26	46	32	46	48	37	38	51	20	37	41	25	34	26	
28	40	30	41	43	35	35	45	18	35	38	23	32	28	
30	35	27	38	38	32	32	40	17	32	35	21	30	30	
32	31	25	35	34	30	29	35	16	29	31	20	27	32	
34	27	23	30	29	28	28	31	15	27	29	19	25	34	
36	24	20	27	26	27	24	28	13	25	26	17	24	36	
38		18	24	23	25	21	25	12	23	23	16	21	38	
40		17	22	21	23	20	22	11	21	21	15	19	40	
42		16	19	18	20	17	19	10	19	19	14	17	42	
44					18	15	18	9	17	16	13	16	44	
46					17	12	15	8	15	15	12	15	46	
48					15	10	14	7	14	13	11	13	48	
50								6	13	11	10	12	50	
52								5.5	11	10	9	11	52	
54											8	10	54	
56											7.5	8	56	
58													58	
Reeving	18	8	12	16	8	10	12	6	8	8	6	6	Reeving	
Wind speed	11.1m/s												Wind speed	
Hook	260t	180t (deadweight 3.3t)						110t (deadweight 3t)						Hook
Telescoping mode	I	2	1	1	2	1	3	2	1	2	3	1	2	I
	II	2	1	2	2	2	2	2	1	3	2	2	3	II
	III	2	2	2	2	2	2	2	2	2	2	2	3	III
	IV	2	2	2	2	2	2	2	3	2	2	3	2	IV
	V	1	2	2	2	2	2	2	3	2	2	3	2	V
	VI	1	3	2	1	3	1	2	3	2	2	3	2	VI

Table 10-3 Main boom (7 sections) 

Unit: t

Main boom 17.8m – 92m, outrigger fully extended (12m x 12m), over full range, 115t counterweight																
Radius (m)	Main boom (m)													Radius (m)		
	62.3★	67.4	67.6	67.8★	72.9	73.1	73.2★	78.5	78.5	78.8★	84.1★	87.7★	92★			
11	75													11		
12	70	50	62	62										12		
14	66	42	55	60	49	52	52							14		
16	58	38	50	55	42	48	50	42	42	42				16		
18	52	35	46	50	36	42	46	38	40	40	37	32	32	18		
20	48	32	42	46	30	37	42	34	36	38	34	29	30	20		
22	43	29	38	41	29	35	40	31	34	36	31	27	27	22		
24	39	26	36	38	26	31	35	29	32	34	29	25	25	24		
26	35	24	32	34	25	30	33	27	30	31	27	23	23	26		
28	32	22	30	31	24	27	30	26	28	28	25	21	21	28		
30	29	20	28	29	22	25	27	23	26	26	23	19	20	30		
32	27	19	26	26	21	23	25	22	25	24	21	18	18	32		
34	25	18	24	24	20	22	24	20	23	22	20	17	17	34		
36	23	17	22	22	19	20	21	18	21	20	18	16	16	36		
38	21	15	20	20	18	19	20	17	20	19	17	14	15	38		
40	19	14	18	18	17	18	18	16	19	18	15	14	14	40		
42	17	13	17	17	15	16	17	15	18	16	14	13	13	42		
44	15	12	15	15	14	15	15	14	16	15	14	12	12	44		
46	13	11	13	13	14	14	14	13	15	13	13	11	11	46		
48	12	10	12	12	12	12	12	12	13	12	11	10	10	48		
50	11	10	12	11	11	11	11	11	13	12	10	9.2	10	50		
52	10	9	11	10	11	11	10	10	12	11	9	9	9	52		
54	8	8	10	9	10	10	9	10	11	10	9	8	8.2	54		
56	7	8	9	8	10	9	9	9	10	9	8	8	8	56		
58		7	8	6	9	8	8	8	9	8	7.6	7	7	58		
60		6	7	5	8	7	7	7	9	7	7	6.5	6.5	60		
62		5	5	4	7	6	6	6.5	8	6	6.5	6	6.2	62		
64		4	4	2.5	6	6	5	6	7	5	5.8	5.6	5.8	64		
66					6	5	4	5.5	6	4	5	5	5.2	66		
68					5	4	3	5	5	3.5	4.6	5	5	68		
70								4	4	3	4	4.2	4.2	70		
72											3	3.2	3	72		
Reeving	6	6	6	6	4	4	4	4	4	4	4	4	4	Reeving		
Wind speed	9m/s													Wind speed		
Hook	110t (deadweight 3t)					50t (deadweight 1.9t)								Hook		
Telescoping mode	I	3	1	2	3	2	2	3	2	3	3	3	3	4	I	Telescoping mode
	II	3	2	3	3	2	3	3	3	2	3	3	3	4	II	
	III	3	3	3	3	3	3	3	3	3	3	3	3	4	III	
	IV	2	3	3	3	3	3	3	3	3	3	3	4	4	IV	
	V	2	3	2	2	3	3	2	3	3	3	3	4	4	V	
	VI	1	3	2	1	3	2	2	3	3	2	3	4	4	VI	

Table 11-1 Main boom (7 sections) 

Unit: t

Main boom 17.8m – 92m, outrigger fully extended (12m x 12m), over full range, 95t counterweight														
Radius (m)	Main boom (m)												Radius (m)	
	17.8	23.4	23.4	23.4★	28.9	28.9	28.9★	34.2	34.5	34.5★	39.8	40		
3.5	250													3.5
4	245	245	240	245										4
4.5	245	245	235	245	210	245	240							4.5
5	235	235	230	235	205	240	235	128	220	235				5
5.5	230	230	220	230	200	235	230	123	220	230				5.5
6	225	225	210	225	188	230	225	117	210	225	128	175		6
7	220	220	205	220	168	225	215	112	192	215	120	160		7
8	215	215	200	215	151	215	200	107	172	200	114	147		8
9	202	200	188	202	138	200	184	102	154	190	107	132		9
10	185	185	173	185	125	183	168	98	142	180	101	122		10
11	165	162	150	164	114	162	150	91	131	162	94	115		11
12	148	145	135	146	108	145	131	86	119	144	85	107		12
14	112	113	110	114	90	110	106	76	102	112	72	95		14
16		90	90	89	78	88	88	68	86	88	63	82		16
18					68	72	73	60	75	73	54	73		18
20					58	60	62	52	65	62	48	64		20
22					51	50	52	47	55	52	42	56		22
24					42	42	44	43	49	45	38	50		24
26								37	40	38	35	43		26
28								33	32	31	32	38		28
30								28	27	27	29	34		30
32											25	29		32
34											23	26		34
36											22	22		36
Reeving	22	22	22	22	18	22	22	10	20	20	12	16		Reeving
Wind speed	14.1m/s				12.8m/s				11.1m/s					Wind speed
Hook	260t (deadweight 4.2t)													Hook
Telescoping mode	I	1	2	1	1	1	2	1	1	1	2	1	1	I
	II	1	1	1	2	1	2	2	1	2	2	1	2	II
	III	1	1	2	1	2	1	2	1	2	2	2	2	III
	IV	1	1	1	1	2	1	1	2	2	1	2	2	IV
	V	1	1	1	1	1	1	1	2	1	1	2	2	V
	VI	1	1	1	1	1	1	1	2	1	1	2	1	VI

Table 11-2 Main boom (7 sections) 

Unit: t

Main boom 17.8m – 92m, outrigger fully extended (12m x 12m), over full range, 95t counterweight														
Radius (m)	Main boom (m)												Radius (m)	
	40.1★	45.1	45.4	45.6★	50.7	51.1	50.9★	56.2	56.5	56.5★	61.8	62.1		
6	200												6	
7	190	86	130	175									7	
8	175	81	124	165	85	115	125						8	
9	160	75	118	153	80	110	124	55	92	92			9	
10	150	70	112	142	76	103	118	50	90	90			10	
11	135	65	106	136	72	95	114	48	82	85	56	72	11	
12	130	60	99	128	68	87	110	43	78	82	52	68	12	
14	110	54	86	110	62	76	98	40	70	74	48	61	14	
16	92	48	77	94	55	66	90	36	62	65	42	54	16	
18	77	42	68	79	50	58	80	32	56	60	38	49	18	
20	66	40	60	69	46	51	67	28	52	54	34	46	20	
22	55	36	55	58	42	46	57	25	48	50	31	40	22	
24	46	34	49	50	39	42	49	23	44	46	28	37	24	
26	40	32	46	43	37	38	42	20	37	41	25	34	26	
28	34	30	40	37	35	35	38	18	35	38	23	32	28	
30	29	27	35	32	32	30	33	17	32	35	21	30	30	
32	25	25	31	27	30	26	29	16	29	31	20	27	32	
34	22	23	28	25	28	23	26	15	27	25	19	25	34	
36	20	20	25	21	27	20	23	13	24	22	17	24	36	
38		18	22	19	24	17	21	12	20	19	16	21	38	
40		17	20	16	21	15	18	11	18	17	15	19	40	
42		16	18	15	19	13	16	10	16	15	14	16	42	
44					17	11	14	9	14	13	13	14.5	44	
46					16	10	13	8	12.5	12	12	12.8	46	
48					14	8	11	7	11	10	11	11	48	
50								6	9.6	9	10	10	50	
52								5	8.5	7.5	9	9	52	
54											8	7.5	54	
56											7	6.5	56	
58													58	
Reeving	18	8	12	16	8	10	12	6	8	8	6	6	Reeving	
Wind speed	11.1m/s												Wind speed	
Hook	260	180t (deadweight 3.3t)						110t (deadweight 3t)						Hook
Telescoping mode	I	2	1	1	2	1	3	2	1	2	3	1	2	I
	II	2	1	2	2	2	2	2	1	3	2	2	3	II
	III	2	2	2	2	2	2	2	2	2	2	2	3	III
	IV	2	2	2	2	2	2	2	3	2	2	3	2	IV
	V	1	2	2	2	2	2	2	3	2	2	3	2	V
	VI	1	3	2	1	3	1	2	3	2	2	3	2	VI

Table 11-3 Main boom (7 sections) 

Unit: t

Main boom 17.8m – 92m, outrigger fully extended (12m x 12m), over full range, 95t counterweight															
Radius (m)	Main boom (m)													Radius (m)	
	62.3★	67.4	67.6	67.8★	72.9	73.1	73.2★	78.5	78.5	78.8★	84.1★	87.7★	92★		
11	75													11	
12	70	50	62	62										12	
14	66	42	55	60	49	52	52							14	
16	58	38	50	55	42	48	50	42	42	42				16	
18	52	35	46	50	36	42	46	38	40	40	37	32	32	18	
20	48	32	42	46	30	37	42	34	36	38	34	29	30	20	
22	43	29	38	41	29	35	40	31	34	36	31	27	27	22	
24	39	26	36	38	26	31	35	29	32	34	29	25	25	24	
26	35	24	32	34	25	30	33	27	30	31	27	23	23	26	
28	32	22	30	31	24	27	30	26	28	28	25	21	21	28	
30	29	20	28	29	22	25	27	23	26	26	23	19	20	30	
32	27	19	26	26	21	23	25	22	25	24	21	18	18	32	
34	24	18	24	24	20	22	24	20	23	22	20	17	17	34	
36	21	17	22	22	19	20	21	18	21	20	18	16	16	36	
38	18	15	20	20	18	19	20	17	20	19	17	14	15	38	
40	15.6	14	18	18	17	18	18	16	19	18	15	14	14	40	
42	14	13	17	14.5	15	16	17	15	18	16	14	13	13	42	
44	12	12	15	13	14	15	15	14	16	15	14	12	12	44	
46	10	11	13	11	14	14	12.5	13	15	13	13	11	11	46	
48	9	10	12	9.5	12	12	11	12	13	12	11	10	10	48	
50	7.4	10	10.7	8	11	11	9.5	11	12	10.5	10	9.2	10	50	
52	6	9	9	7	11	10	8.5	10	10.5	9	9	9	9	52	
54	5.2	8	8	6	10	9	7	10	9.6	8	9	8	8	54	
56	4	8	7	5	10	8	6	9	8.5	7	8	8	8	56	
58		7	6	4	8.5	7	5	8	7.5	6	7	7	7	58	
60		6	5	3	7.5	6	4.5	7.4	6.5	5	6.4	6.5	6.2	60	
62		5	4	2	6.5	5.5	3.6	6.5	5.8	4.5	5.5	6	5.7	62	
64		4	3		6	4.6	3	5.5	5	3.5	4.8	5	5	64	
66					5	4	2	5	4.3	2.8	4	4.5	4	66	
68					4.5	3		4	3.5	2	3	3.6	3.6	68	
70											2.7	3	3	70	
72														72	
Reeving	6	6	6	6	4	4	4	4	4	4	4	4	4	Reeving	
Wind speed	9m/s													Wind speed	
Hook	110t (deadweight 3t)						50t (deadweight 1.9t)						Hook		
Telescoping mode	I	3	1	2	3	2	2	3	2	3	3	3	3	4	I
	II	3	2	3	3	2	3	3	3	2	3	3	3	4	II
	III	3	3	3	3	3	3	3	3	3	3	3	3	4	III
	IV	2	3	3	3	3	3	3	3	3	3	3	4	4	IV
	V	2	3	2	2	3	3	2	3	3	3	3	4	4	V
	VI	1	3	2	1	3	2	2	3	3	2	3	4	4	VI

Table 12-1 Main boom (7 sections) 

Unit: t

Main boom 17.8m – 92m, outrigger fully extended (12m x 12m), over full range, 80t counterweight														
Radius (m)	Main boom (m)												Radius (m)	
	17.8	23.4	23.4	23.4★	28.9	28.9	28.9★	34.2	34.5	34.5★	39.8	40		
3.5	250												3.5	
4	245	245	240	245									4	
4.5	245	245	235	245	210	245	240						4.5	
5	235	235	230	235	205	240	235	128	220	235			5	
5.5	230	230	220	230	200	235	230	123	220	230			5.5	
6	225	225	210	225	188	230	225	117	210	225	128	175	6	
7	220	220	205	220	168	225	215	112	192	215	120	160	7	
8	215	215	200	215	151	215	200	107	172	200	114	147	8	
9	200	200	188	202	138	200	184	102	154	190	107	132	9	
10	180	180	170	180	125	182	168	98	142	178	101	122	10	
11	156	154	140	155	114	152	145	91	130	155	94	115	11	
12	135	133	125	134	108	130	120	86	118	132	85	107	12	
14	103	103	103	103	85	98	89	76	100	100	72	95	14	
16		86	88	87	73	77	77	68	76	79	61	80	16	
18					62	62	63	58	65	64	54	64	18	
20					52	51	51	50	54	52	48	56	20	
22					45	42	44	46	45	44	40	48	22	
24					38	35	37	41	39	37	38	41	24	
26								35	33	31	35	35	26	
28								33	28	25	30	28	28	
30								27	25	20	27	25	30	
32											25	22	32	
34											22	18	34	
36											19	17	36	
Reeving	22	22	22	22	18	22	22	10	20	20	12	16	Reeving	
Wind speed	14.1m/s				12.8m/s			11.1m/s					Wind speed	
Hook	260t (deadweight 4.2t)												Hook	
Telescoping mode	I	1	2	1	1	1	2	1	1	1	2	1	1	I
	II	1	1	1	2	1	2	2	1	2	2	1	2	II
	III	1	1	2	1	2	1	2	1	2	2	2	2	III
	IV	1	1	1	1	2	1	1	2	2	1	2	2	IV
	V	1	1	1	1	1	1	1	2	1	1	2	2	V
	VI	1	1	1	1	1	1	1	2	1	1	2	1	VI

Table 12-2 Main boom (7 sections) 

Unit: t

Main boom 17.8m – 92m, outrigger fully extended (12m x 12m), over full range, 80t counterweight														
Radius (m)	Main boom (m)												Radius (m)	
	40.1★	45.1	45.4	45.6★	50.7	51.1	50.9★	56.2	56.5	56.5★	61.8	62.1		
6	200												6	
7	190	86	130	175									7	
8	175	81	124	165	85	115	125						8	
9	160	75	118	153	80	110	124	55	92	92			9	
10	150	70	112	142	76	103	118	50	90	90			10	
11	135	65	106	136	72	95	114	48	82	85	56	72	11	
12	130	60	99	128	68	87	110	43	78	82	52	68	12	
14	103	54	82	106	62	76	98	40	70	74	48	61	14	
16	82	48	70	84	55	66	85	36	62	65	42	54	16	
18	66	42	62	69	50	58	71	32	56	60	38	49	18	
20	55	40	55	57	46	51	60	28	52	54	34	46	20	
22	46	36	49	48	42	46	51	25	46	47.5	31	40	22	
24	39	34	43	41	39	43	44	23	41	42	28	38	24	
26	33	32	38	35	35	36	37	20	35.5	36	25	34	26	
28	26	30	34	30	33	31	34	18	31	32	23	30	28	
30	24	25	28	26	29	25	28	17	26.5	26	21	27	30	
32	21	23	25	23	26	24	25	16	23	23	20	24	32	
34	17	22	21	20	23	19	22	15	20	20	18	21	34	
36	15	20	19	17	21	16	19	13	17.5	17	17	19	36	
38		18	17	15	18	14	17	12	15	15	16	17	38	
40		16	15	13	16	11	14	11	13	13	14	14	40	
42		14	13	11	14	9	12	10	11	11	13	13	42	
44					13	7	10	9	9	9	12	11	44	
46					11	6	9	8	8	8	11	9	46	
48					9	5	7	6.5	6	6	10	8	48	
50								5	5	5	9	7	50	
52								4.2	4	4	8	6	52	
54											7	5	54	
56											6	4	56	
58													58	
Reeving	18	8	12	16	8	10	12	6	8	8	6	6	Reeving	
Wind speed	11.1m/s												Wind speed	
Hook	260	180t (deadweight 3.3t)						110t (deadweight 3t)						Hook
Telescoping mode	I	2	1	1	2	1	3	2	1	2	3	1	2	I
	II	2	1	2	2	2	2	2	1	3	2	2	3	II
	III	2	2	2	2	2	2	2	2	2	2	2	3	III
	IV	2	2	2	2	2	2	2	3	2	2	3	2	IV
	V	1	2	2	2	2	2	2	3	2	2	3	2	V
	VI	1	3	2	1	3	1	2	3	2	2	3	2	VI

Table 12-3 Main boom (7 sections) 

Unit: t

Main boom 17.8m – 92m, outrigger fully extended (12m x 12m), over full range, 80t counterweight														
Radius (m)	Main boom (m)													Radius (m)
	62.3★	67.4	67.6	67.8★	72.9	73.1	73.2★	78.5	78.5	78.8★	84.1★	87.7★	92★	
11	75													11
12	70	50	62	62										12
14	66	42	55	60	49	52	52							14
16	58	38	50	55	42	48	50	42	42	42				16
18	52	35	46	50	36	42	46	38	40	40	37	32	32	18
20	48	32	42	46	30	37	42	34	36	38	34	29	30	20
22	43	29	38	41	29	35	40	31	34	36	31	27	27	22
24	39	26	36	38	26	31	35	29	32	34	29	25	25	24
26	35	24	32	33	25	30	33	27	30	31	27	23	23	26
28	31	22	30	30	24	27	30	26	28	28	25	21	21	28
30	27	20	27	28	22	25	27	23	26	26	23	19	20	30
32	23	19	25	26	21	23	25	22	25	24	21	18	18	32
34	20	18	23	22	20	22	24	20	23	22	20	17	17	34
36	17	17	21	19	19	20	20	18	21	20	18	16	15.5	36
38	14	15	17	16	18	19	18	17	20	19	17	14	14	38
40	11	14	16	14	17	17	15	16	19	17	15	13	13	40
42	10	13	14	11	15	15	13	15	16	15	13	12	12	42
44	9	12	12	9	14	13	10.5	14	13	12	12	11.5	11	44
46	7	11	10	7	12	11	9	13	12	10	11	11	10.5	46
48	6	10	9	6.5	11	10	8	11	10	9	10	10	9.5	48
50	5	9.5	8	5	10	9	6.5	10	8	8	8.5	9	8.6	50
52	3	9	6.5	4	9	7	5	9	8	6	7.2	8	7.5	52
54	2	8	5	3	7	6	4	7.8	6.5	5.2	6.5	7	6.5	54
56		7.5	4	2.5	6	5	3.5	6.5	5.5	4	5.5	6	5.7	56
58		7	3		5.5	4.5	3	5.5	5	3.5	4.7	5.2	5	58
60		6	2.5		5	4	2	4.5	4.6	3	4	4.4	4	60
62		5	2		4.5	3.3		3.5	3.3	2	3.2	3.5	3.5	62
64		4			4	2.5		3	2.6		2.6	3	2.8	64
66								2	2		2	2.4	2.2	66
68												1.8	1.6	68
Reeving	6	6	6	6	4	4	4	4	4	4	4	4	4	Reeving
Wind speed	9m/s													Wind speed
Hook	110t (deadweight 3t)						50t (deadweight 1.9t)						Hook	
Telescoping mode	I	3	1	2	3	2	2	3	2	3	3	3	3	I
	II	3	2	3	3	2	3	3	3	2	3	3	3	II
	III	3	3	3	3	3	3	3	3	3	3	3	3	III
	IV	2	3	3	3	3	3	3	3	3	3	3	4	IV
	V	2	3	2	2	3	3	2	3	3	3	3	4	V
	VI	1	3	2	1	3	2	2	3	3	2	3	4	4

Table 13-1 Main boom (7 sections) 

Unit: t

Main boom 17.8m – 92m, outrigger fully extended (12m x 12m), over full range, 50t counterweight														
Radius (m)	Main boom (m)												Radius (m)	
	17.8	23.4	23.4	23.4★	28.9	28.9	28.9★	34.2	34.5	34.5★	39.8	40		
3.5	250												3.5	
4	245	245	240	245									4	
4.5	245	245	235	245	210	245	240						4.5	
5	235	235	230	235	205	240	235	128	220	235			5	
5.5	230	230	220	230	200	235	230	123	220	230			5.5	
6	225	225	210	225	188	230	225	117	210	225	128	175	6	
7	220	220	205	220	168	225	215	112	192	215	120	160	7	
8	215	215	200	215	151	215	200	107	172	200	114	147	8	
9	180	178	175	179	138	175	174	102	154	175	107	132	9	
10	147	148	145	147	122	141	138	98	140	143	101	122	10	
11	122	122	120	125	110	119	117	91	120	123	94	115	11	
12	103	98	102	100	98	103	101	86	106	108	85	103	12	
14	79	72	76	74	74	75	77	75	86	85	72	84	14	
16		55	59	57	64	61	62	60	66	64	60	70	16	
18					52	48	51	51	50	49	53	58	18	
20					42	36	40	45	43	40	45	45	20	
22					32	26	30	38	36	33	39	38	22	
24					25	21	23	31	30	26	33	31	24	
26								25	24	20	29	26	26	
28								20	19	16	26	22	28	
30								18	15	11	22	18	30	
32											18	15	32	
34											15	12	34	
36											12	10	36	
Reeving	22	22	22	22	18	22	22	10	20	20	12	16	Reeving	
Wind speed	14.1m/s				12.8m/s				11.1m/s				Wind speed	
Hook	260t (deadweight 4.2t)												Hook	
Telescoping mode	I	1	2	1	1	1	2	1	1	1	2	1	1	I
	II	1	1	1	2	1	2	2	1	2	2	1	2	II
	III	1	1	2	1	2	1	2	1	2	2	2	2	III
	IV	1	1	1	1	2	1	1	2	2	1	2	2	IV
	V	1	1	1	1	1	1	1	2	1	1	2	2	V
	VI	1	1	1	1	1	1	1	2	1	1	2	1	VI

Table 13-2 Main boom (7 sections) 

Unit: t

Main boom 17.8m – 92m, outrigger fully extended (12m x 12m), over full range, 50t counterweight														
Radius (m)	Main boom (m)												Radius (m)	
	40.1★	45.1	45.4	45.6★	50.7	51.1	50.9★	56.2	56.5	56.5★	61.8	62.1		
6	200												6	
7	190	86	130	175									7	
8	175	81	124	165	85	115	125						8	
9	160	75	118	153	80	110	124	55	92	92			9	
10	145	70	112	142	76	103	118	50	90	90			10	
11	123	65	106	126	72	95	114	48	82	85	56	72	11	
12	109	60	99	107	68	87	104	43	78	82	52	68	12	
14	88	54	79	81	62	76	84	40	70	74	48	61	14	
16	67	48	66	65	55	66	66	36	62	64	42	54	16	
18	48	42	57	56	49	56	54	32	51	51	38	49	18	
20	39	40	49	46	44	43	43	28	42	42	33	43	20	
22	31	36	40	37	38	34	37	23	35	35	30	37	22	
24	26	32	33	29	33	28	33	22	28	30	28	32	24	
26	21	28	29	22	28	23	28	20	24	25	24	27	26	
28	17	25	24	20	24	18	22	18	20	21	23	23	28	
30	14	21	20	17	20	15	18	17	15	16	21	18	30	
32	11	18	16	12	19	11	15	15	13	14	19	16	32	
34	8	16	14	10	16	9	12	14	11	11	18	14	34	
36	7	14	11	9	13	8	10	12	9	9	15.5	12	36	
38		12	10	7	11	7	9	10	7.8	7	13.4	10	38	
40		10	8	5	9	5	7	9	6.7	6	11.7	8	40	
42		8	6	4	7.5	3.5	6	7.5	5.6	5	10.5	6.2	42	
44					6.5	2	5	6.4	4.7	4	8.7	4.6	44	
46					5.3		4	5.3	3.6	3	7.5	3.5	46	
48					4.2		3	4	2.6	2	6.6	2	48	
50								3			5.5		50	
52											4.4		52	
54											3		54	
Reeving	18	8	12	16	8	10	12	6	8	8	6	6	Reeving	
Wind speed	11.1m/s												Wind speed	
Hook	260t	180t (deadweight 3.3t)						110t (deadweight 3t)						Hook
Telescoping mode	I	2	1	1	2	1	3	2	1	2	3	1	2	I
	II	2	1	2	2	2	2	2	1	3	2	2	3	II
	III	2	2	2	2	2	2	2	2	2	2	2	3	III
	IV	2	2	2	2	2	2	2	3	2	2	3	2	IV
	V	1	2	2	2	2	2	2	3	2	2	3	2	V
	VI	1	3	2	1	3	1	2	3	2	2	3	2	VI

Table 13-3 Main boom (7 sections) 

Unit: t

Main boom 17.8m – 92m, outrigger fully extended (12m x 12m), over full range, 50t counterweight															
Radius (m)	Main boom (m)													Radius (m)	
	62.3★	67.4	67.6	67.8★	72.9	73.1	73.2★	78.5	78.5	78.8★	84.1★	87.7★	92★		
11	75													11	
12	70	50	62	62										12	
14	66	42	55	60	49	52	52							14	
16	58	38	50	55	42	48	50	42	42	42				16	
18	51	35	46	50	36	42	46	38	40	40	37	32	32	18	
20	43	32	42	44	30	37	42	34	36	38	34	29	30	20	
22	37	29	38	39	29	35	40	31	34	35	31	27	27	22	
24	30	26	33	31	26	30	31	29	31	32	29	25	25	24	
26	24	24	28	25	25	28	26	27	28	27	27	22	23	26	
28	19	22	23	20	23	24	22	23	23	22	23	21	21	28	
30	16	20	19	16	22	21	19	20.5	20	18.5	20	19	19.5	30	
32	12	19	16	12	19	18	15	18	17	15.5	17	17	17	32	
34	10	18	13	11	17	15	13	15.5	14.8	13	14.5	15	14.5	34	
36	9	16	11	9	14.5	13	11	13.4	12.5	11	12.5	13	12.7	36	
38	6.5	13	10	8	12.6	11	9	11.5	11	9.5	10.6	11	11	38	
40	5	12	8	6.5	11	9.5	7.5	10	9	8	9	9.5	9.3	40	
42	3.7	11	7	5	9.5	8	6.2	8.5	8	6.5	7.7	8	8	42	
44	2	10	5.4	3	8	7	5	7	6.5	5.5	6.5	7	6.5	44	
46		8	4.6	2	7	5.6	3.7	6	5.2	4	5.2	6	5.5	46	
48		7	3.2		6	4.5	2.6	5	4.5	3.4	4.2	4.8	4.5	48	
50		6	2.5		5	3.5	1.8	4	3.5	2.2	3.5	3.9	3.5	50	
52		5			4	2.8		3.5	2.5		2.6	3	2.5	52	
54		4			3.2	2		2.5	2			2	2	54	
56		3			2.4			2						56	
Reeving	6	6	6	6	4	4	4	4	4	4	4	4	4	Reeving	
Wind speed	9m/s													Wind speed	
Hook	110t (deadweight 3t)					50t (deadweight 1.9t)								Hook	
Telescoping mode	I	3	1	2	3	2	2	3	2	3	3	3	3	4	I
	II	3	2	3	3	2	3	3	3	2	3	3	3	4	II
	III	3	3	3	3	3	3	3	3	3	3	3	3	4	III
	IV	2	3	3	3	3	3	3	3	3	3	3	4	4	IV
	V	2	3	2	2	3	3	2	3	3	3	3	4	4	V
	VI	1	3	2	1	3	2	2	3	3	2	3	4	4	VI

Table 14-1 Main boom (7 sections) 

Unit: t

Main boom 17.8m – 92m, outrigger fully extended (12m x 12m), over full range, 0t counterweight														
Radius (m)	Main boom (m)												Radius (m)	
	17.8	23.4	23.4	23.4★	28.9	28.9	28.9★	34.2	34.5	34.5★	39.8	40		
3.5	250												3.5	
4	245	245	240	245									4	
4.5	245	245	235	245	210	245	240						4.5	
5	235	235	230	235	205	240	235	128	220	235			5	
5.5	230	230	220	230	200	235	230	123	220	230			5.5	
6	225	225	210	225	188	225	220	117	210	220	128	175	6	
7	181	175	172	175	168	173	172	112	170	170	120	160	7	
8	142	141	138	142	135	135	135	107	130	131	114	128	8	
9	122	121	120	121	116	115	115	102	108	112	98	100	9	
10	96	91	90	92	94	92	92	90	93	92	80	82	10	
11	74	75	74	76	75	73	73	68	66	64	65	64	11	
12	54	54	55	56	55	52	52	56	55	52	50	50	12	
14	35	30	33	33	32	32	30	37	33	30	45	37	14	
16		20	22	24	24	20	22	26	24	22	32	30	16	
18					18	12	15	18	16	12	22	18	18	
20					13	9	12	16	12	9	18	15	20	
22										5	13	10	22	
24											10	7	24	
Reeving	22	22	22	22	18	22	22	10	20	20	12	16	Reeving	
Wind speed	14.1m/s				12.8m/s				11.1m/s				Wind speed	
Hook	260t (deadweight 4.2t)												Hook	
Telescoping mode	I	1	2	1	1	1	2	1	1	1	2	1	1	I
	II	1	1	1	2	1	2	2	1	2	2	1	2	II
	III	1	1	2	1	2	1	2	1	2	2	2	2	III
	IV	1	1	1	1	2	1	1	2	2	1	2	2	IV
	V	1	1	1	1	1	1	1	2	1	1	2	2	V
	VI	1	1	1	1	1	1	1	2	1	1	2	1	VI

Table 14-2 Main boom (7 sections) 

Unit: t

Main boom 17.8m – 92m, outrigger fully extended (12m x 12m), over full range, 0t counterweight														
Radius (m)	Main boom (m)												Radius (m)	
	40.1★	45.1	45.4	45.6★	50.7	51.1	50.9★	56.2	56.5	56.5★	61.8	62.1		
6	200												6	
7	168	86	130	175									7	
8	128	81	124	130	85	115	125						8	
9	100	75	100	100	80	110	115	55	92	92			9	
10	80	70	84	80	76	103	100	50	90	90			10	
11	64	65	65	62	69	71	70	48	80	85	56	72	11	
12	51	53	55	50	56	54	58	43	57	55	52	62	12	
14	32	38	34	28	38	32	35	32	36	34	35	33	14	
16	22	28	27	20	30	24	25	26	25	24	32	29	16	
18	14	21	17	13	23	18	21	23	19	20	21	19	18	
20	10	18	16	10	18	16	17	19	15	13	18	14	20	
22	8	14	13	8	13	9	12	17	11	10	14	12	22	
24	4	12	19	6	10	5	8	14	7	6	11	8	24	
26		10	9	4	8		5	11	5		10	5	26	
28		7	6		5			8			6		28	
30											5		30	
Reeving	18	8	12	16	8	10	12	6	8	8	6	6	Reeving	
Wind speed	11.1m/s												Wind speed	
Hook	260	180t (deadweight 3.3t)						110t (deadweight 3t)						Hook
Telescoping mode	I	2	1	1	2	1	3	2	1	2	3	1	2	I
	II	2	1	2	2	2	2	2	1	3	2	2	3	II
	III	2	2	2	2	2	2	2	2	2	2	2	3	III
	IV	2	2	2	2	2	2	2	3	2	2	3	2	IV
	V	1	2	2	2	2	2	2	3	2	2	3	2	V
	VI	1	3	2	1	3	1	2	3	2	2	3	2	VI

Table 14-3 Main boom (7 sections) 

Unit: t

Main boom 17.8m – 92m, outrigger fully extended (12m x 12m), over full range, 0t counterweight															
Radius (m)	Main boom (m)													Radius (m)	
	62.3★	67.4	67.6	67.8★	72.9	73.1	73.2★	78.5	78.5	78.8★	84.1★	87.7★	92★		
11	75													11	
12	62	50	62	62										12	
14	32	40	42	41	49	50	48	35	34	31				14	
16	22	33	30	28	34	32	31	32	32	31	36			16	
18	18	24	22	20	25	23	22	23	21	20	23	24	24	18	
20	13	18	15	14	17	15	14	16	14	15	17	18	17	20	
22	9	18	14	10	15	13	10	13	12	12	14	15	15	22	
24	5	13	9	6	11	11	8	9	8	7	10	11	10	24	
26		11	6		8	6	4	8	7	5	7	8	8	26	
28		7			6			6	5			5	5	28	
Reeving	6	6	6	6	4	4	4	4	4	4	4	2	2	Reeving	
Wind speed	9m/s													Wind speed	
Hook	110t (deadweight 3t)					50t (deadweight 1.9t)								Hook	
Telescoping mode	I	3	1	2	3	2	2	3	2	3	3	3	3	4	I
	II	3	2	3	3	2	3	3	3	2	3	3	3	4	II
	III	3	3	3	3	3	3	3	3	3	3	3	3	4	III
	IV	2	3	3	3	3	3	3	3	3	3	3	4	4	IV
	V	2	3	2	2	3	3	2	3	3	3	3	4	4	V
	VI	1	3	2	1	3	2	2	3	3	2	3	4	4	VI

Table 15-1 Main boom (7 sections) 

Unit: t

Main boom 17.8m – 92m, outrigger intermediately extended (9.4m x 10.4m), over full range, 0t counterweight														
Radius (m)	Main boom (m)												Radius (m)	
	17.8	23.4	23.4	23.4★	28.9	28.9	28.9★	34.2	34.5	34.5★	39.8	40		
3.5	210												3.5	
4	200	210	210	210									4	
4.5	190	200	200	200	180	200	200						4.5	
5	175	190	190	190	160	185	185	115	190	200			5	
5.5	168	175	175	160	145	170	170	110	175	185			5.5	
6	145	140	145	135	110	135	125	105	130	140	110	135	6	
7	102	94	98	100	100	95	98	93	102	98	90	105	7	
8	80	70	72	75	75	70	72	75	76	76	80	81	8	
9	55	55	57	58	58	56	57	59	59	56	62	60	9	
10	45	42	43	45	45	42	44	47	46	42	50	48	10	
11	38	32	35	38	35	32	34	37	36	35	40	38	11	
12	28	25	27	29	27	24	26	29	28	26	30	28	12	
14	18	17	18	19	18	15	17	18	17	15	22	20	14	
16		11	12	13	10	8	9	13	12	10	15	14	16	
18					6	6	5	8	7	6	9	8	18	
20								6	6	5	7	6	20	
22											5	4	22	
24											4	3	24	
Reeving	18	18	18	18	16	18	18	10	18	18	10	10	Reeving	
Wind speed	14.1m/s				12.8m/s				11.1m/s				Wind speed	
Hook	260t (deadweight 4.2t)												Hook	
Telescoping mode	I	1	2	1	1	1	2	1	1	1	2	1	1	I
	II	1	1	1	2	1	2	2	1	2	2	1	2	II
	III	1	1	2	1	2	1	2	1	2	2	2	2	III
	IV	1	1	1	1	2	1	1	2	2	1	2	2	IV
	V	1	1	1	1	1	1	1	2	1	1	2	2	V
	VI	1	1	1	1	1	1	1	2	1	1	2	1	VI

Table 15-2 Main boom (7 sections) 

Unit: t

Main boom 17.8m – 92m, outrigger intermediately extended (9.4m x 10.4m), over full range, 0t counterweight														
Radius (m)	Main boom (m)												Radius (m)	
	40.1★	45.1	45.4	45.6★	50.7	51.1	50.9★	56.2	56.5	56.5★	61.8	62.1		
6	150													6
7	105	80	100	110										7
8	78	64	85	85	65	84	88							8
9	57	59	65	65	62	65	70	45	65	62				9
10	45	50	52	51	55	52	53	42	52	50				10
11	35	44	42	40	45	42	42	40	42	40	38	42		11
12	25	36	34	33	38	35	36	35	35	33	30	35		12
14	17	25	23	22	28	24	16	25	23	20	25	23		14
16	12	18	16	15	20	17	18	18	17	15	18	17		16
18	7	12	11	10	14	12	13	12	11	10	12	10		18
20	5	8	7	6	10	8	9	8	7	7	8	7		20
22	4	5	4	3	7		6	6	5	5	7	6		22
24		4			5		5	5	4	4	6	5		24
26														26
Reeving	16	8	10	14	8	10	10	6	8	8	8	8		Reeving
Wind speed	11.1m/s													Wind speed
Hook	180t (deadweight 3.3t)						110t (deadweight 3t)						Hook	
Telescoping mode	I	2	1	1	2	1	3	2	1	2	3	1	2	I
	II	2	1	2	2	2	2	2	1	3	2	2	3	II
	III	2	2	2	2	2	2	2	2	2	2	2	3	III
	IV	2	2	2	2	2	2	2	3	2	2	3	2	IV
	V	1	2	2	2	2	2	2	3	2	2	3	2	V
	VI	1	3	2	1	3	1	2	3	2	2	3	2	VI

Table 15-3 Main boom (7 sections) 

Unit: t

Main boom 17.8m – 92m, outrigger intermediately extended (9.4m x 10.4m), over full range, 0t counterweight															
Radius (m)	Main boom (m)													Radius (m)	
	62.3★	67.4	67.6	67.8★	72.9	73.1	73.2★	78.5	78.5	78.8★	84.1★	87.7★	92★		
11	40													11	
12	32	40	38	36										12	
14	23	30	28	26	28	27	25	27	26	25				14	
16	17	21	20	18	21	20	18	20	20	18	20			16	
18	10	16	14	12	16	15	13	15	16	14	15	16	15	18	
20	8	11	10	9	11	11	10	12	12	10	10	12	12	20	
22		9	8		8	7	6	9	9	7	9	9	9	22	
24		7			7	6	3	7	6	5	6	6	6	24	
26		5			5			5	4					26	
Reeving	4	4	4	3	3	3	3	3	3	3	2	2	2	Reeving	
Wind speed	9m/s													Wind speed	
Hook	50t (deadweight 1.9t)													Hook	
Telescoping mode	I	3	1	2	3	2	2	3	2	3	3	3	3	4	I
	II	3	2	3	3	2	3	3	3	2	3	3	3	4	II
	III	3	3	3	3	3	3	3	3	3	3	3	3	4	III
	IV	2	3	3	3	3	3	3	3	3	3	3	4	4	IV
	V	2	3	2	2	3	3	2	3	3	3	3	4	4	V
	VI	1	3	2	1	3	2	2	3	3	2	3	4	4	VI

Lifting capacity tables / Lifting height charts

7-section main boom + superlift OM: 34.5m – 92m

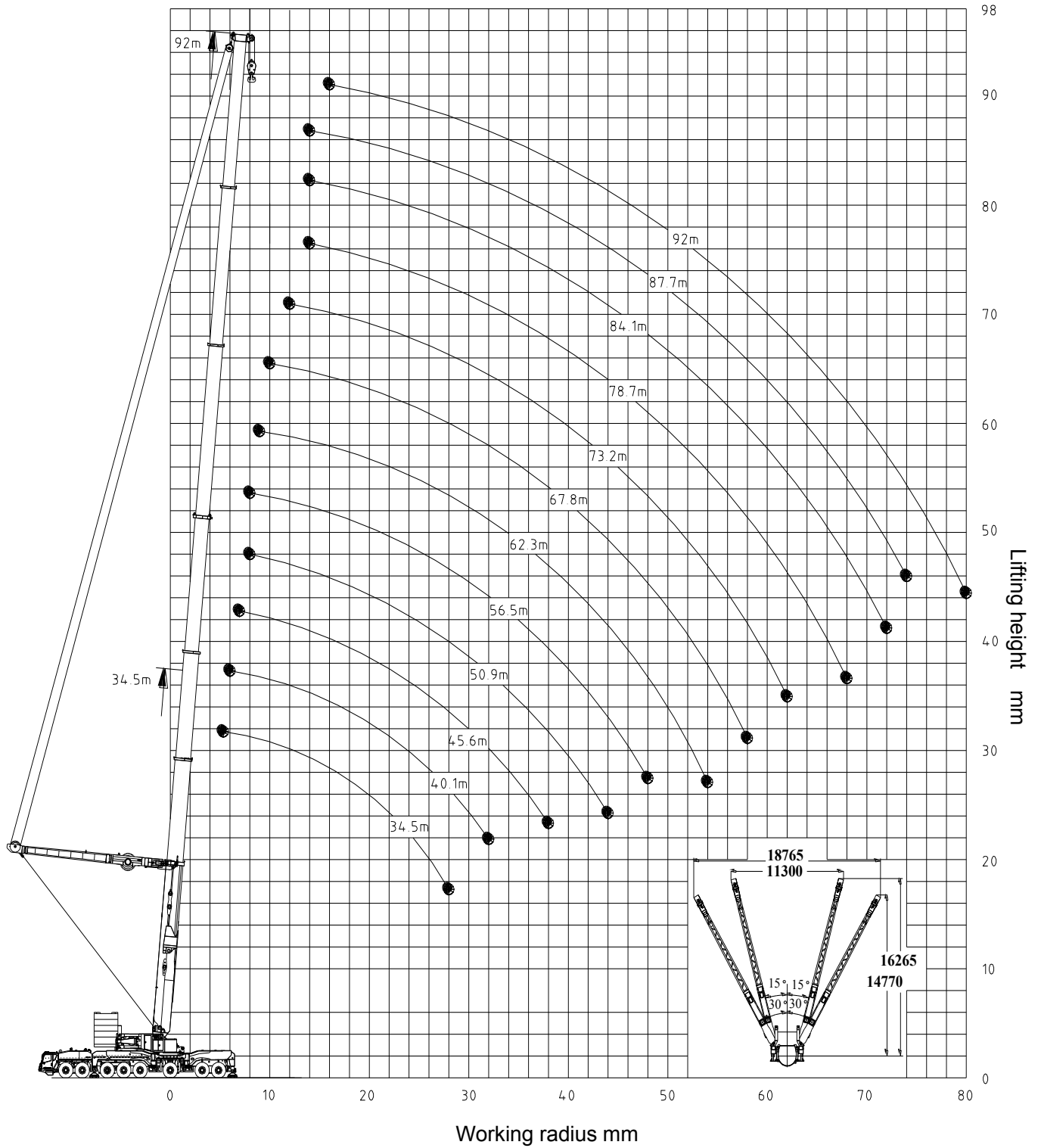

Table 16-1 Superlift + Main boom (7 sections)



Unit: t

Main boom 34.5m – 92m, outrigger fully extended (12m x 12m), over full range, 195t counterweight Boom length ≥ 62.3m, angle of superlift single edge 30° ; Boom length < 62.3m, angle of superlift single edge 15°														
Radius (m)	Main boom (m)												Radius (m)	
	34.2	34.5	34.5★	39.8	40	40.1★	45.1	45.4	45.6★	50.7	51.1	50.9★		
5	185	235	235										5	
5.5	175	235	235										5.5	
6	165	225	225	185	215	215							6	
7	155	205	205	175	210	210	170	185	205				7	
8	150	200	200	170	205	205	164	175	205	160	195	170	8	
9	145	195	195	165	195	195	160	170	200	155	190	160	9	
10	135	192	185	158	185	185	156	165	190	148	180	155	10	
11	130	184	175	152	170	175	145	158	183	140	170	150	11	
12	126	174	172	145	160	162	138	152	175	136	160	150	12	
14	122	150	145	120	130	150	125	134	152	126	146	142	14	
16	115	131	129	100	115	135	110	124	135	117	134	135	16	
18	105	117	116	95	105	118	95	110	121	108	119	120	18	
20	100	104	102	90	95	107	89	98	110	98	108	110	20	
22	92	92	90	86	97	96	84	92	99	90	97	99	22	
24	81	82	82	84	87	86	79	91	90	82	88	89	24	
26	71	72	70	78	77	77	72	83	82	74	80	82	26	
28	61	61	62	70	65	68	67	73	72	68	71	72	28	
30				62	57	60	62	65	64	60	63	63	30	
32				55	54	53	57	58	56	57	56	56	32	
34							53	53	51	53	50	51	34	
36							46	45	44	47	45	46	36	
38							43	42	41	42	40	41	38	
40										39	36	38	40	
42										34	32	33	42	
44										30	28	29	44	
Reeving	18	20	20	18	20	20	16	16	18	14	17	16	Reeving	
Wind speed	11.1m/s												Wind speed	
Hook	260t (deadweight 4.2t)												Hook	
Telescoping mode	I	1	1	2	1	1	2	1	1	2	1	3	2	I
	II	1	2	2	1	2	2	1	2	2	2	2	2	II
	III	1	2	2	2	2	2	2	2	2	2	2	2	III
	IV	2	2	1	2	2	2	2	2	2	2	2	2	IV
	V	2	1	1	2	2	1	2	2	2	2	2	2	V
	VI	2	1	1	2	1	1	3	2	1	3	1	2	VI

Table 16-2 Superlift + Main boom (7 sections)



Unit: t

Main boom 34.5m – 92m, outrigger fully extended (12m x 12m), over full range, 195t counterweight Boom length ≥ 62.3m, angle of superlift single edge 30° ; Boom length < 62.3m, angle of superlift single edge 15°															
Radius (m)	Main boom (m)												Radius (m)		
	56.2	56.5	56.5★	61.8	62.1	62.3★	67.4	67.6	67.8★	72.9	73.1	73.2★			
8	150	170	170										8		
9	145	165	165	125	140	160							9		
10	143	155	155	120	134	150	125	135	150				10		
11	138	150	150	115	130	155	120	130	140				11		
12	132	145	145	110	125	140	115	125	130	98	105	115	12		
14	118	130	135	105	122	130	108	115	120	96	98	110	14		
16	108	120	125	100	115	120	100	105	110	90	92	102	16		
18	98	108	114	96	105	110	96	100	105	84	85	98	18		
20	88	100	103	92	98	102	88	92	98	81	82	94	20		
22	80	92	92	86	90	91	81	85	90	78	79	86	22		
24	74	83	84	80	82	83	74	76	83	74	75	80	24		
26	68	77	77	71	75	75	70	72	74	68	68	74	26		
28	63	69	70	65	68	69	64	68	69	65	65	68	28		
30	58	62	64	58	62	63	60	63	64	60	60	63	30		
32	53	56	58	55	58	59	55	58	59	57	57	58	32		
34	48	52	52	50	53	52	50	53	54	54	53	55	34		
36	44	47	47	46	48	47	47	48	49	48	47	49	36		
38	39	43	42	44	44	43	43	44	44	45	45	45	38		
40	35	39	38	41	40	39	40	41	40	42	41	42	40		
42	36	37	35	38	36	35	36	36	36	38	38	38	42		
44	33	32	31	35	34	32	35	34	33	36	35	35	44		
46	28	27	26	32	30	29	32	31	30	32	31	31	46		
48	24	24	23	29	27	26	29	28	27	30	29	29	48		
50				27	26	24	27	26	25	27	26	26	50		
52				24	22	21	23	22	22	26	25	24	52		
54				21	19	19	21	20	20	23	22	22	54		
56							19	18	18	21	20	20	56		
58							17	16	16	19	18	18	58		
60										17	16	16	60		
62										16	15	15	62		
Reeving	12	14	14	10	12	13	10	10	12	10	10	10	Reeving		
Wind speed	11.1m/s			9m/s									Wind speed		
Hook	180t (deadweight 3.3t)												Hook		
Telescoping mode	I	1	2	3	1	2	3	1	2	3	2	2	3	I	Telescoping mode
	II	1	3	2	2	3	3	2	3	3	2	3	3	II	
	III	2	2	2	2	3	3	3	3	3	3	3	3	III	
	IV	3	2	2	3	2	2	3	3	3	3	3	3	IV	
	V	3	2	2	3	2	2	3	2	2	3	3	2	V	
	VI	3	2	2	3	2	1	3	2	1	3	2	2	VI	

Table 16-3 Superlift + Main boom (7 sections)



Unit: t

Main boom 34.5m – 92m, outrigger fully extended (12m x 12m), over full range, 195t counterweight Boom length \geq 62.3m, angle of superlift single edge 30° ; Boom length $<$ 62.3m, angle of superlift single edge 15°									
Radius (m)	Main boom (m)						Radius (m)		
	78.5	78.5	78.8★	84.1★	87.7★	92★			
14	94	95	102	85	75		14		
16	92	93	95	85	75	70	16		
18	85	86	90	82	73	70	18		
20	80	83	86	82	72	66	20		
22	74	79	82	79	70	64	22		
24	71	75	76	72	68	62	24		
26	69	70	72	66	63	60	26		
28	64	65	65	63	59	58	28		
30	60	61	61	58	55	55	30		
32	56	57	57	53	51	51	32		
34	52	53	53	50	48	45	34		
36	48	50	50	48	46	42	36		
38	44	46	46	45	44	40	38		
40	41	43	42	43	41	38	40		
42	39	41	40	40	39	37	42		
44	34	36	36	37	36	35	44		
46	33	34	33	34	33	33	46		
48	31	30	31	32	31	31	48		
50	28	27	28	29	29	30	50		
52	25	25	25	26	27	28	52		
54	24	23	24	24	25	26	54		
56	23	22	22	23	23	24	56		
58	21	20	20	21	21	22	58		
60	19	18	18	19	19	21	60		
62	17	16	16	18	17	19	62		
64	15	14	14	16	16	17	64		
66	14	13	13	14	14	15	66		
68	13	12	12	13	13	14	68		
70				12	12	13	70		
72				11	11	12	72		
74					10	11	74		
76						10	76		
78						9	78		
80						8	80		
Reeving	8	8	8	8	6	6	Reeving		
Wind speed	9m/s						Wind speed		
Hook	110t (deadweight 3t)						Hook		
Telescoping mode	I	2	3	3	3	3	4	I	Telescoping mode
	II	3	2	3	3	3	4	II	
	III	3	3	3	3	3	4	III	
	IV	3	3	3	3	4	4	IV	
	V	3	3	3	3	4	4	V	
	VI	3	3	2	3	4	4	VI	

Table 17-1 Superlift + Main boom (7 sections)



Unit: t

Main boom 34.5m – 92m, outrigger fully extended (12m x 12m), over full range, 155t counterweight Boom length ≥ 62.3m, angle of superlift single edge 30° ; Boom length < 62.3m, angle of superlift single edge 15°														
Radius (m)	Main boom (m)												Radius (m)	
	34.2	34.5	34.5★	39.8	40	40.1★	45.1	45.4	45.6★	50.7	51.1	50.9★		
5	185	235	235										5	
5.5	175	235	235										5.5	
6	165	225	225	185	215	215							6	
7	155	205	205	175	210	210	170	185	205				7	
8	150	200	200	170	205	205	164	175	205	160	195	170	8	
9	145	195	195	165	195	195	160	170	200	155	190	160	9	
10	135	185	185	158	180	180	156	165	190	148	180	155	10	
11	130	175	175	152	170	170	145	158	183	140	170	150	11	
12	126	167	167	145	160	160	138	152	175	136	160	147	12	
14	122	143	143	120	130	145	125	134	152	126	144	140	14	
16	115	125	125	100	115	128	110	124	135	117	132	130	16	
18	100	108	102	92	100	112	95	110	116	105	118	116	18	
20	95	94	94	86	95	97	89	98	100	93	96	100	20	
22	80	79	79	84	83	82	84	88	87	82	85	86	22	
24	68	67	67	72	71	70	75	76	75	73	72	74	24	
26	59	58	58	62	61	60	66	66	66	65	63	64	26	
28	50	49	49	54	53	52	58	58	58	58	57	57	28	
30				47	46	45	51	50	50	51	50	50	30	
32				41	41	40	45	44	44	45	44	44	32	
34							41	40	40	40	39	39	34	
36							36	35	35	35	34	34	36	
38							32	31	31	31	30	30	38	
40										28	26.5	27	40	
42										24	23.5	24	42	
44										21	20	20	44	
Reeving	18	20	20	18	20	20	16	16	18	14	16	16	Reeving	
Wind speed	11.1m/s												Wind speed	
Hook	260t (deadweight 4.2t)												Hook	
Telescoping mode	I	1	1	2	1	1	2	1	1	2	1	3	2	I
	II	1	2	2	1	2	2	1	2	2	2	2	2	II
	III	1	2	2	2	2	2	2	2	2	2	2	2	III
	IV	2	2	1	2	2	2	2	2	2	2	2	2	IV
	V	2	1	1	2	2	1	2	2	2	2	2	2	V
	VI	2	1	1	2	1	1	3	2	1	3	1	2	VI

Table 17-2 Superlift + Main boom (7 sections)



Unit: t

Main boom 34.5m – 92m, outrigger fully extended (12m x 12m), over full range, 155t counterweight Boom length ≥ 62.3m, angle of superlift single edge 30° ; Boom length < 62.3m, angle of superlift single edge 15°															
Radius (m)	Main boom (m)												Radius (m)		
	56.2	56.5	56.5★	61.8	62.1	62.3★	67.4	67.6	67.8★	72.9	73.1	73.2★			
8	150	170	170										8		
9	145	165	165	125	140	160							9		
10	143	155	155	120	134	150	125	135	150				10		
11	138	150	150	115	130	155	120	130	140				11		
12	132	148	148	110	125	140	115	125	130	98	105	115	12		
14	118	130	135	105	120	130	108	115	120	96	98	108	14		
16	108	120	125	100	115	120	100	105	110	90	90	100	16		
18	98	108	112	96	105	110	96	100	105	84	85	96	18		
20	88	100	101	92	98	102	88	92	96	81	82	92	20		
22	80	86	88	86	90	91	81	85	88	78	79	86	22		
24	74	76	77	73	77	77	74	76	79	74	75	80	24		
26	63	67	67	65	68	67	65	68	68	68	68	70	26		
28	54	57	57	60	60	59	60	60	60	60	60	60	28		
30	50	51	51	54	53	53	54	54	54	54	54	52	30		
32	46	45	45	48	47	47	48	48	47	50	48	46	32		
34	41	41	41	42	41	40	43	43	42	44	44	42	34		
36	37	36.5	36	38	37	36	39	38	37	40	40	38	36		
38	33	32.6	32	33	32	32	35	34	33	30	29	28	38		
40	30	29	29	31	31	30	32	31	30	28	27	25	40		
42	27	26	26	28	27	26.5	29	28	27	25	24	23	42		
44	24	23	23	25	24	24	26	25	24	23	22	21	44		
46	21	21	20.5	22	22	21	23	22	21	22	21	19	46		
48	19	18	18	20	20	19	21	20	19	20	19	18	48		
50				17	17	16.5	18	17	16	19	18	16	50		
52				16	15	14	16	15	14	17	16	15	52		
54				14	14	13	15	14	13	15	15	13	54		
56							13	12	11	14	13	12	56		
58							10	10	9	12	12	11	58		
60										11	11	10	60		
62										10	9	9	62		
Reeving	12	14	14	10	12	13	10	10	12	10	10	10	Reeving		
Wind speed	11.1m/s			9m/s									Wind speed		
Hook	180t (deadweight 3.3t)												Hook		
Telescoping mode	I	1	2	3	1	2	3	1	2	3	2	2	3	I	Telescoping mode
	II	1	3	2	2	3	3	2	3	3	2	3	3	II	
	III	2	2	2	2	3	3	3	3	3	3	3	3	III	
	IV	3	2	2	3	2	2	3	3	3	3	3	3	IV	
	V	3	2	2	3	2	2	3	2	2	3	3	2	V	
	VI	3	2	2	3	2	1	3	2	1	3	2	2	VI	

Table 17-3 Superlift + Main boom (7 sections)



Unit: t

Main boom 34.5m – 92m, outrigger fully extended (12m x 12m), over full range, 155t counterweight Boom length ≥ 62.3m, angle of superlift single edge 30° ; Boom length < 62.3m, angle of superlift single edge 15°										
Radius (m)	Main boom (m)						Radius (m)			
	78.5	78.5	78.8★	84.1★	87.7★	92★				
14	94	95	102	85	75		14			
16	92	93	95	85	75	70	16			
18	85	86	88	79	73	70	18			
20	79	80	82	78	72	66	20			
22	74	75	76	75	70	64	22			
24	71	72	73	70	68	62	24			
26	68	69	70	65	63	60	26			
28	64	65	65	61	59	58	28			
30	60	58	58	56	55	55	30			
32	50	49	48	48	46	46	32			
34	45	44	43	44	44	44	34			
36	41	40	40	40	40	40	36			
38	37	37	36	36.5	37	36.5	38			
40	34	34	33	33.5	34	33	40			
42	31	31	30	31	31	31	42			
44	29	28	28	28	28.5	28	44			
46	26	26	25	26	26.5	26	46			
48	23	22	21	24	24.5	24	48			
50	21	20	20	22	22	22.5	50			
52	19	18	18	20	20	21	52			
54	17	17	16	18	18	19	54			
56	16	15	14	17	16	18	56			
58	15	14	13	15	14	17	58			
60	13	13	12	13	13	15	60			
62	12	11	11	12	12	14	62			
64	11	10	10	11	10	12	64			
66	10	9	9	9	9	11	66			
68	9	9	8	8	8	10	68			
70				7	7	9	70			
72				6	6	8	72			
74					6	7	74			
76						6	76			
Reeving	8	8	8	8	6	6	Reeving			
Wind speed	9m/s						Wind speed			
Hook	110t (deadweight 3t)						Hook			
Telescoping mode	I	2	3	3	3	3	4	I	Telescoping mode	
	II	3	2	3	3	3	3	4		II
	III	3	3	3	3	3	3	4		III
	IV	3	3	3	3	3	4	4		IV
	V	3	3	3	3	3	4	4		V
	VI	3	3	2	3	3	4	4		VI

Table 18-1 Superlift + Main boom (7 sections)



Unit: t

Main boom 34.5m – 92m, outrigger fully extended (12m x 12m), over full range, 135t counterweight Boom length ≥ 62.3m, angle of superlift single edge 30° ; Boom length < 62.3m, angle of superlift single edge 15°														
Radius (m)	Main boom (m)												Radius (m)	
	34.2	34.5	34.5★	39.8	40	40.1★	45.1	45.4	45.6★	50.7	51.1	50.9★		
5	185	235	235										5	
5.5	175	235	235										5.5	
6	165	225	225	185	215	215							6	
7	155	205	205	175	210	210	170	185	205				7	
8	150	200	200	170	205	205	164	175	205	160	195	170	8	
9	145	195	195	165	190	190	160	170	190	155	190	160	9	
10	135	185	185	158	180	180	156	165	175	148	175	155	10	
11	130	175	175	152	170	170	145	155	167	140	165	150	11	
12	126	165	165	145	160	160	138	150	156	135	155	144	12	
14	122	143	143	120	130	142	125	130	136	120	135	130	14	
16	115	125	124	100	115	125	108	112	121	113	120	120	16	
18	102	101	97	92	100	102	95	106	106	100	104	105	18	
20	84	82	80	86	88	87	85	92	90	86	89	90	20	
22	70	68	66	76	75	74	79	79	79	77	77	77	22	
24	59	57	55	65	64	62	69	68	68	67	66	66	24	
26	50	49	47	56	54	52	60	59	59	58	57	57	26	
28	42	41	40	48	47	45	53	52	51	51	50	50	28	
30				41	40	37	47	46	45	45	43	44	30	
32				35	33	30	41	40	39	41	38	39	32	
34							37	36	34.5	35	33	34	34	
36							33	32	30	31	29	30	36	
38							28	27	26	27	25	26	38	
40										24	22	23	40	
42										21	19	20	42	
44										18	16	17	44	
Reeving	18	20	20	18	20	20	16	16	18	14	16	16	Reeving	
Wind speed	11.1m/s												Wind speed	
Hook	260t (deadweight 4.2t)												Hook	
Telescoping mode	I	1	1	2	1	1	2	1	1	2	1	3	2	I
	II	1	2	2	1	2	2	1	2	2	2	2	2	II
	III	1	2	2	2	2	2	2	2	2	2	2	2	III
	IV	2	2	1	2	2	2	2	2	2	2	2	2	IV
	V	2	1	1	2	2	1	2	2	2	2	2	2	V
	VI	2	1	1	2	1	1	3	2	1	3	1	2	VI

Table 18-2 Superlift + Main boom (7 sections)



Unit: t

Main boom 34.5m – 92m, outrigger fully extended (12m x 12m), over full range, 135t counterweight Boom length ≥ 62.3m, angle of superlift single edge 30° ; Boom length < 62.3m, angle of superlift single edge 15°															
Radius (m)	Main boom (m)												Radius (m)		
	56.2	56.5	56.5★	61.8	62.1	62.3★	67.4	67.6	67.8★	72.9	73.1	73.2★			
8	150	170	170										8		
9	145	165	165	125	140	160							9		
10	143	155	155	120	134	150	125	135	150				10		
11	138	150	150	115	130	155	120	130	140				11		
12	132	148	148	110	125	140	115	125	130	98	105	115	12		
14	118	130	130	105	120	130	108	115	120	96	98	108	14		
16	108	115	117	100	115	120	100	105	110	90	90	100	16		
18	94	98	102	96	105	110	96	100	105	84	85	96	18		
20	78	83	86	90	92	92	88	92	90	81	82	92	20		
22	69	75	74	77	78	80	75	78	80	76	78	80	22		
24	65	67	68	69	68	68	66	68	70	69	70	70	24		
26	60	60	59	60	58	58	62	60	62	63	62	63	26		
28	53	53	52	53	51	51	55	55	54	55.5	54	55	28		
30	47	47	46	47	46	46	49	48	48	49	49	49	30		
32	41.5	41	40	41	39	38	44	42	42	44	44	44	32		
34	38	37	35.5	36	34	34	40	38	37	39	39	39	34		
36	33	32	31	32	30	30	35	33	33	37	36	35	36		
38	29	28.5	28	28	26	26	32	30	29	33	32	31	38		
40	26	25	24	25	24	23	29	28	26	30	29	28	40		
42	23	22	21	22	21	21	26	25	23	28	27	25	42		
44	20.4	20	19	19	18	18	23	22	20	25	24	22	44		
46	18	17	16.5	17	16	15	21	20	18	23	22	20	46		
48	15.6	15	14	15	14	13	19	17	16	20	19	17.5	48		
50				13	12	11	17	15	14	18	18	15.5	50		
52				11	11	10	15	14	12	17	16	13.5	52		
54				10	10	9	12	12	10	15	14	11.8	54		
56							10	9	8	13	12	10	56		
58							8	7	7	11	10	9	58		
60										10	9	7.4	60		
62										8	7	6	62		
Reeving	12	14	14	10	12	13	10	10	12	10	10	10	Reeving		
Wind speed	11.1m/s			9m/s									Wind speed		
Hook	180t (deadweight 3.3t)												Hook		
Telescoping mode	I	1	2	3	1	2	3	1	2	3	2	2	3	I	Telescoping mode
	II	1	3	2	2	3	3	2	3	3	2	3	3	II	
	III	2	2	2	2	3	3	3	3	3	3	3	3	III	
	IV	3	2	2	3	2	2	3	3	3	3	3	3	IV	
	V	3	2	2	3	2	2	3	2	2	3	3	2	V	
	VI	3	2	2	3	2	1	3	2	1	3	2	2	VI	

Table 18-3 Superlift + Main boom (7 sections)



Unit: t

Main boom 34.5m – 92m, outrigger fully extended (12m x 12m), over full range, 135t counterweight Boom length \geq 62.3m, angle of superlift single edge 30° ; Boom length < 62.3m, angle of superlift single edge 15°								
Radius (m)	Main boom (m)						Radius (m)	
	78.5	78.5	78.8★	84.1★	87.7★	92★		
14	94	95	102	85	75		14	
16	92	93	95	80	75	70	16	
18	85	86	88	79	73	70	18	
20	79	80	82	78	72	66	20	
22	74	75	76	75	70	64	22	
24	71	72	73	70	68	62	24	
26	65	64	65	64	60	60	26	
28	57	56	56	57	56	56	28	
30	51	51	51	51	51	51	30	
32	45	45	45	46	46	46	32	
34	41.5	41	41	41	42	41	34	
36	37	36	36	37	38	37	36	
38	34	33	33	34	34	34	38	
40	31	30	30	31	31	31	40	
42	28	27	27	28	28	28	42	
44	26	25	25	25	25	26	44	
46	23.5	23	23	23	23	24	46	
48	21	20	20	21	20	21	48	
50	19	18	18	19	18	19	50	
52	17.5	17	17	17	16	17	52	
54	16	15	15	15	15	16	54	
56	14	13.5	13	13	13	15	56	
58	12	12	12	12	11	14	58	
60	11	11	11	10	10	12	60	
62	10	9.5	9	9	9	11	62	
64	9	8.2	8.4	8	7.5	10	64	
66	8.3	8	8	7	6.4	8.5	66	
68	8	7.5	7	6	5.5	7.4	68	
70				5	4.5	6.4	70	
72				4	3.5	5.5	72	
74						4	74	
Reeving	8	8	8	8	6	6	Reeving	
Wind speed	9m/s						Wind speed	
Hook	110t (deadweight 3t)						Hook	
Telescoping mode	I	2	3	3	3	3	4	I
	II	3	2	3	3	3	4	II
	III	3	3	3	3	3	4	III
	IV	3	3	3	3	4	4	IV
	V	3	3	3	3	4	4	V
	VI	3	3	2	3	4	4	VI

Table 19-1 Superlift + Main boom (7 sections)



Unit: t

Main boom 34.5m – 92m, outrigger fully extended (12m x 12m), over full range, 115t counterweight Boom length ≥ 62.3m, angle of superlift single edge 30° ; Boom length < 62.3m, angle of superlift single edge 15°														
Radius (m)	Main boom (m)												Radius (m)	
	34.2	34.5	34.5★	39.8	40	40.1★	45.1	45.4	45.6★	50.7	51.1	50.9★		
5	185	235	235										5	
5.5	175	235	235										5.5	
6	165	225	225	185	215	215							6	
7	155	205	205	175	210	210	170	185	205				7	
8	150	200	200	170	200	200	164	175	205	160	195	170	8	
9	145	195	195	165	190	190	160	170	190	155	190	160	9	
10	135	185	185	158	180	180	156	165	175	148	175	155	10	
11	130	175	175	152	170	170	145	155	167	140	165	150	11	
12	121	160	160	145	160	160	138	150	156	135	155	144	12	
14	117	138	135	120	138	135	125	130	132	120	135	130	14	
16	110	110	110	100	116	115	108	112	121	113	115	116	16	
18	90	89	88	92	94	93	95	99	98	93	95	96	18	
20	73	72	72	77	76	75	83	83	82	81	80	80	20	
22	61	60	59	66	66	65	71	70	70	69	68	68	22	
24	51	50	49	55	54	53	61	60	60	60	58	59	24	
26	42	42	41	47	47	46	52	51	51	51	50	50	26	
28	35	35	34	40	40	39	45	44	44	45	43	44	28	
30				34	34	33	38	37	37	39	37	38	30	
32				29	29	28	34	33	32	35	32	34	32	
34							29	28	28	29	27	28	34	
36							25	24	24	26	24	25	36	
38							21	20	19	22	20	21	38	
40										18	17	18	40	
42										15	14	15	42	
44										13	12	13	44	
Reeving	18	20	20	18	20	20	16	16	18	14	16	16	Reeving	
Wind speed	11.1m/s												Wind speed	
Hook	260t (deadweight 4.2t)												Hook	
Telescoping mode	I	1	1	2	1	1	2	1	1	2	1	3	2	I
	II	1	2	2	1	2	2	1	2	2	2	2	2	II
	III	1	2	2	2	2	2	2	2	2	2	2	2	III
	IV	2	2	1	2	2	2	2	2	2	2	2	2	IV
	V	2	1	1	2	2	1	2	2	2	2	2	2	V
	VI	2	1	1	2	1	1	3	2	1	3	1	2	VI

Table 19-2 Superlift + Main boom (7 sections)



Unit: t

Main boom 34.5m – 92m, outrigger fully extended (12m x 12m), over full range, 115t counterweight Boom length ≥ 62.3m, angle of superlift single edge 30° ; Boom length < 62.3m, angle of superlift single edge 15°															
Radius (m)	Main boom (m)												Radius (m)		
	56.2	56.5	56.5★	61.8	62.1	62.3★	67.4	67.6	67.8★	72.9	73.1	73.2★			
8	150	170	170										8		
9	145	165	165	125	140	160							9		
10	143	155	155	120	134	150	125	135	150				10		
11	138	150	150	115	130	155	120	130	140				11		
12	132	148	148	110	125	140	115	125	130	98	105	115	12		
14	118	130	130	105	120	130	108	115	120	96	98	108	14		
16	108	115	117	100	110	110	100	105	110	90	90	100	16		
18	94	96	98	92	95	98	96	100	100	84	85	96	18		
20	78	79	78	83	83	82	82	85	84	81	82	84	20		
22	70	69	68	71	71	70	72	71	70	72	71	70	22		
24	60	59	58	61	61	60	62	62	61	63	62	61	24		
26	52	51	50	53	53	53	55	54	54	56	55	55	26		
28	46	45	45	46	46	45	50	48	47	49	48	48	28		
30	40	39	39	41	40	40	44	42	41	44	43	43	30		
32	36	34	34	36	35	35	40	38	36	39	38	38	32		
34	32	29	29	32	31	31	36	34	32	34	33	33	34		
36	29	26	26	29	28	27	32	31	28	30	29	29	36		
38	25	23	23	26	25	23	29	27	26	27	26	26	38		
40	23	20	20	23	22	20	26	24	23	25	24	23	40		
42	17	16	16	19	19	18	24	22	21	22	21	20	42		
44	15	14	14	18	17	16	22	20	19	21	20	18	44		
46	14	12	12	15	14	13	20	18	17	19	18	16	46		
48	13	11	10	14	12	12	17	16	15	17	16	14	48		
50				12	11	10	13	13	12	15	14	13	50		
52				11	9	8	12	11	11	14	12	11	52		
54				10	8	7	11	10	10	11	10	8.5	54		
56							9	9	8	10	9	7.5	56		
58							8	6	6	9	8	6	58		
60										8	7	5	60		
62										6.5	6	4.5	62		
Reeving	12	14	14	10	12	13	10	10	12	10	10	10	Reeving		
Wind speed	11.1m/s			9m/s									Wind speed		
Hook	180t (deadweight 3.3t)												Hook		
Telescoping mode	I	1	2	3	1	2	3	1	2	3	2	2	3	I	Telescoping mode
	II	1	3	2	2	3	3	2	3	3	2	3	3	II	
	III	2	2	2	2	3	3	3	3	3	3	3	3	III	
	IV	3	2	2	3	2	2	3	3	3	3	3	3	IV	
	V	3	2	2	3	2	2	3	2	2	3	3	2	V	
	VI	3	2	2	3	2	1	3	2	1	3	2	2	VI	

Table 19-3 Superlift + Main boom (7 sections)



Unit: t

Main boom 34.5m – 92m, outrigger fully extended (12m x 12m), over full range, 115t counterweight Boom length \geq 62.3m, angle of superlift single edge 30° ; Boom length $<$ 62.3m, angle of superlift single edge 15°										
Radius (m)	Main boom (m)						Radius (m)			
	78.5	78.5	78.8★	84.1★	87.7★	92★				
14	94	95	102	85	75		14			
16	92	93	95	80	75	70	16			
18	85	86	88	79	73	70	18			
20	79	80	82	78	72	66	20			
22	72	72	72	75	70	64	22			
24	64	64	63	65	68	62	24			
26	56	55	54	58	57	57	26			
28	50	49	49	51	51	51	28			
30	45	45	44	45	45	45	30			
32	40	40	39	41	40	41	32			
34	36	35	35	35	34	34	34			
36	32	31	31	31	31	31	36			
38	29	28	27	28	28	28	38			
40	27	27	25	26	25.5	26	40			
42	25	25	23	24	23	23.5	42			
44	23	23	21	21.4	21	21	44			
46	20	21	19	18.6	18	18	46			
48	18	19	17	17	16.6	16.8	48			
50	16	16	15	15.5	15	15.2	50			
52	15	15	14	14.4	14	14	52			
54	14	13	12	13	12.8	13	54			
56	12	11	10	12	11.7	12	56			
58	10	10	9	10	10	10	58			
60	9	9	8	9	9	9.3	60			
62	8	8	7	8.5	8	8.4	62			
64	7	7	6	7.5	7.3	7.6	64			
66	7	6	5	7	6.5	6.8	66			
68	6.5	6	5	6	5.4	6	68			
70				5	4.6	5.4	70			
72				4	3.5	4.5	72			
Reeving	8	8	8	8	6	6	Reeving			
Wind speed	9m/s						Wind speed			
Hook	110t (deadweight 3t)						Hook			
Telescoping mode	I	2	3	3	3	3	4	I	Telescoping mode	
	II	3	2	3	3	3	3	4		II
	III	3	3	3	3	3	3	4		III
	IV	3	3	3	3	3	4	4		IV
	V	3	3	3	3	3	4	4		V
	VI	3	3	2	3	3	4	4		VI

Table 20-1 Superlift + Main boom (7 sections)



Unit: t

Main boom 34.5m – 92m, outrigger fully extended (12m x 12m), over full range, 95t counterweight Boom length ≥ 62.3m, angle of superlift single edge 30° ; Boom length < 62.3m, angle of superlift single edge 15°														
Radius (m)	Main boom (m)												Radius (m)	
	34.2	34.5	34.5★	39.8	40	40.1★	45.1	45.4	45.6★	50.7	51.1	50.9★		
5	185	235	235										5	
5.5	175	235	235										5.5	
6	165	225	225	185	215	215							6	
7	155	205	205	175	210	210	170	185	205				7	
8	150	200	200	170	200	200	164	175	205	160	195	170	8	
9	145	195	195	165	190	190	160	170	190	155	190	160	9	
10	135	185	185	158	180	180	156	165	175	148	175	155	10	
11	130	175	175	152	170	170	145	155	167	140	165	150	11	
12	121	160	160	145	160	160	138	150	156	135	155	144	12	
14	114	122	120	118	121	120	110	120	125	120	130	130	14	
16	97	96	95	100	98	98	96	104	102	98	102	100	16	
18	79	79	78	82	80	80	85	83	82	83	80	81	18	
20	65	64	63	67	66	66	71	70	69	70	69	70	20	
22	55	53	51	58	57	56	61	61	60	58	58	58	22	
24	47	45	43	49	49	48	52	51	50	50	49	50	24	
26	41	38	36	43	41	40	45	45	44	44	43	44	26	
28	33	31	29	38	36	34	40	39	37	38	37	37	28	
30				32	31	29	36	34	32	34	33	33	30	
32				27	26	24	32	30	28	29	29	28	32	
34							28	26	24	26	25	25	34	
36							25	24	21	21	20	20	36	
38							19	18	18	20	18	19	38	
40										16	15	16	40	
42										15	13	14	42	
44										13	11	12	44	
Reeving	18	20	20	18	20	20	16	16	18	14	16	16	Reeving	
Wind speed	11.1m/s												Wind speed	
Hook	260t (deadweight 4.2t)												Hook	
Telescoping mode	I	1	1	2	1	1	2	1	1	2	1	3	2	I
	II	1	2	2	1	2	2	1	2	2	2	2	2	II
	III	1	2	2	2	2	2	2	2	2	2	2	2	III
	IV	2	2	1	2	2	2	2	2	2	2	2	2	IV
	V	2	1	1	2	2	1	2	2	2	2	2	2	V
	VI	2	1	1	2	1	1	3	2	1	3	1	2	VI

Table 20-2 Superlift + Main boom (7 sections)



Unit: t

Main boom 34.5m – 92m, outrigger fully extended (12m x 12m), over full range, 95t counterweight Boom length \geq 62.3m, angle of superlift single edge 30° ; Boom length < 62.3m, angle of superlift single edge 15°														
Radius (m)	Main boom (m)												Radius (m)	
	56.2	56.5	56.5★	61.8	62.1	62.3★	67.4	67.6	67.8★	72.9	73.1	73.2★		
8	150	170	170										8	
9	145	165	165	125	140	160							9	
10	143	155	155	120	134	150	125	135	150				10	
11	138	150	150	115	130	155	120	130	140				11	
12	132	148	148	110	125	140	115	125	130	98	105	115	12	
14	118	130	130	105	120	130	108	115	120	96	98	108	14	
16	100	104	105	100	102	102	98	102	106	90	90	100	16	
18	82	86	85	87	86	83	88	92	86	82	84	85	18	
20	72	72	72	74	73	73	74	74	72	75	74	73	20	
22	63	62	60	63	62	62	64	64	63	65	64	62	22	
24	54	53	52	55	54	53	55	54	54	57	56	55	24	
26	47	47	45	50	48	46	48	47	46	50	49	48	26	
28	42	40	39	45	43	40	44	43	40	43	42	41	28	
30	36	35	33	39	37	35	40	39	35	38	37	36	30	
32	31	30	29	36	34	31	35	34	31	35	33	32	32	
34	29	28	26	31	30	28	32	31	27	29	28	28	34	
36	27	25	23	28	26	24	29	28	24	26	25	24	36	
38	21	19	18	25	24	22	25	23	21	25	24	22	38	
40	20	17	15	22	21	19	23	22	19	21	20	19	40	
42	18	15	14	20	17	16	21	20	17	19	18	17	42	
44	15	13	12	16	15	15	19	18	15	18	16	16	44	
46	13	11	11	14	13	12	17	16	13	16	15	13	46	
48	11	10	9	13	11	10	15	14	11	14	14	12	48	
50				11	10	8	12	12	9	13	12	10	50	
52				10	8	7	11	10	8	11	11	9	52	
54				9	7	6	10	9	7	10	9	8	54	
56							8	8	6	9	8	7	56	
58							7	5	5	8	7	6	58	
60										7	6	5	60	
62										6	5	4	62	
Reeving	12	14	14	10	12	13	10	10	12	10	10	10	Reeving	
Wind speed	11.1m/s			9m/s									Wind speed	
Hook	180t (deadweight 3.3t)												Hook	
Telescoping mode	I	1	2	3	1	2	3	1	2	3	2	2	3	I
	II	1	3	2	2	3	3	2	3	3	2	3	3	II
	III	2	2	2	2	3	3	3	3	3	3	3	3	III
	IV	3	2	2	3	2	2	3	3	3	3	3	3	IV
	V	3	2	2	3	2	2	3	2	2	3	3	2	V
	VI	3	2	2	3	2	1	3	2	1	3	2	2	VI

Table 20-3 Superlift + Main boom (7 sections)



Unit: t

Main boom 34.5m – 92m, outrigger fully extended (12m x 12m), over full range, 95t counterweight Boom length \geq 62.3m, angle of superlift single edge 30° ; Boom length $<$ 62.3m, angle of superlift single edge 15°										
Radius (m)	Main boom (m)						Radius (m)			
	78.5	78.5	78.8★	84.1★	87.7★	92★				
14	94	95	102	85	75		14			
16	92	93	95	80	75	70	16			
18	82	84	85	79	73	70	18			
20	78	76	73	75	72	66	20			
22	67	66	65	66	66	66	22			
24	58	57	55	57	58	57	24			
26	51	50	50	50	50.5	50	26			
28	45	44	44	44	44	44	28			
30	39	38	38	39	39	39	30			
32	35	35	34	35	35	35	32			
34	32	32	31	31	32	31	34			
36	29	29	28	28	29	28	36			
38	26	25	25	25	26	25	38			
40	23	22	22	23	23	23	40			
42	21	20	20	21	21	21	42			
44	19	18	18	19	19	18.7	44			
46	17	16	16	17	17.5	17	46			
48	16	15	15	15.6	16	15.6	48			
50	15	14	14	14	14.5	14	50			
52	13	12	12	13	13	12.8	52			
54	12	11	11	11.5	12	11.5	54			
56	11	10	9.8	10.5	11	10.5	56			
58	9.5	9	8.5	9	9.4	9	58			
60	8.5	8	7.5	8	8	8	60			
62	7.4	7	6	7	7.2	7	62			
64	6.5	6	5	6	6.4	6	64			
66	6	5	4.2	5	5.4	5.5	66			
68	5	4.5	3.4	4.5	4	4.5	68			
70				3.6	3.5	4	70			
72				3	2.6	2.5	72			
Reeving	8	8	8	8	6	6	Reeving			
Wind speed	9m/s						Wind speed			
Hook	110t (deadweight 3t)						Hook			
Telescoping mode	I	2	3	3	3	3	4	I	Telescoping mode	
	II	3	2	3	3	3	3	4		II
	III	3	3	3	3	3	3	4		III
	IV	3	3	3	3	3	4	4		IV
	V	3	3	3	3	3	4	4		V
	VI	3	3	2	3	3	4	4		VI

Table 21-1 Superlift + Main boom (7 sections)



Unit: t

Main boom 34.5m – 92m, outrigger fully extended (12m x 12m), over full range, 80t counterweight Boom length ≥ 62.3m, angle of superlift single edge 30° ; Boom length < 62.3m, angle of superlift single edge 15°														
Radius (m)	Main boom (m)												Radius (m)	
	34.2	34.5	34.5★	39.8	40	40.1★	45.1	45.4	45.6★	50.7	51.1	50.9★		
5	185	235	235										5	
5.5	175	235	235										5.5	
6	165	225	225	185	215	215							6	
7	155	205	205	175	210	210	170	185	205				7	
8	150	200	200	170	200	200	164	175	205	160	195	170	8	
9	145	195	195	165	190	190	160	170	190	155	190	160	9	
10	135	182	182	158	180	180	156	165	175	148	175	155	10	
11	130	168	168	152	170	170	145	155	167	140	165	150	11	
12	120	149	147	127	152	153	115	121	154	135	155	144	12	
14	110	109	107	116	116	114	108	118	118	110	116	118	14	
16	86	87	83	91	91	88	90	93	91	94	93	93	16	
18	72	70	66	73	73	71	77	77	75	78	75	77	18	
20	60	58	55	63	62	59	66	65	63	66	61	64	20	
22	51	49	46	55	53	50	57	55	53	55	52	54	22	
24	43	41	38	45	45	42	50	48	46	49	45	47	24	
26	37	35	32	40	39	36	42	40	39	40	38	39	26	
28	31	28	26	35	32	31	37	35	32	37	34	35	28	
30				31	28	26	33	31	28	33	29	31	30	
32				25	24	22	29	28	24	27	25	25	32	
34							26	24	20	25	23	25	34	
36							22	20	18	20	18	19	36	
38							18	17	15	19	16	17	38	
40										15	13	14	40	
42										13	11	12	42	
44										12	10	11	44	
Reeving	18	20	20	18	20	20	16	16	18	14	16	16	Reeving	
Wind speed	11.1m/s												Wind speed	
Hook	260t (deadweight 4.2t)												Hook	
Telescoping mode	I	1	1	2	1	1	2	1	1	2	1	3	2	I
	II	1	2	2	1	2	2	1	2	2	2	2	2	II
	III	1	2	2	2	2	2	2	2	2	2	2	2	III
	IV	2	2	1	2	2	2	2	2	2	2	2	2	IV
	V	2	1	1	2	2	1	2	2	2	2	2	2	V
	VI	2	1	1	2	1	1	3	2	1	3	1	2	VI

Table 21-2 Superlift + Main boom (7 sections)



Unit: t

Main boom 34.5m – 92m, outrigger fully extended (12m x 12m), over full range, 80t counterweight Boom length ≥ 62.3m, angle of superlift single edge 30° ; Boom length < 62.3m, angle of superlift single edge 15°															
Radius (m)	Main boom (m)												Radius (m)		
	56.2	56.5	56.5★	61.8	62.1	62.3★	67.4	67.6	67.8★	72.9	73.1	73.2★			
8	150	170	170										8		
9	145	165	165	125	140	160							9		
10	143	155	155	120	134	150	125	135	150				10		
11	138	150	150	115	130	155	120	130	140				11		
12	132	148	148	110	125	140	115	125	130	98	105	115	12		
14	104	112	115	105	120	120	108	115	120	96	98	108	14		
16	91	95	94	93	94	92	94	96	96	90	90	92	16		
18	80	77	76	77	77	76	77	80	79	80	79	78	18		
20	70	64	63	64	65	65	69	67	65	68	67	66	20		
22	60	54	53	55	55	55	60	59	56	58	57	57	22		
24	52	47	45	51	50	47	52	50	47	51	49	49	24		
26	46	40	39	47	43	41	45	44	41	44	42	42	26		
28	40	35	34	42	38	35	41	38	36	40	39	37	28		
30	34	31	30	36	33	31	37	34	31	36	34	32	30		
32	30	27	27	33	30	27	33	30	28	32	31	29	32		
34	28	24	23	29	26	24	29	27	24	28	26	25	34		
36	25	22	21	26	23	21	26	24	21	25	24	22	36		
38	20	18	17	23	21	18	24	21	19	23	22	20	38		
40	19	16	14	20	17	16	21	19	17	20	19	18	40		
42	18	14	13	19	16	14	19	17	15	18	17	16	42		
44	14	12	11	16	14	12	17	15	13	17	15	14	44		
46	13	11	10	13	12	10	15	13	11	15	14	12.5	46		
48	11	9	8	12	10.5	8	13	11	9	13	12	11	48		
50				10	9	7	11	10	8	12	11	9.5	50		
52				9	7	5	10	9	6	10	9	8	52		
54				8	6	4	9	7	5	9	8	7	54		
56							8	6	4	8	7	6	56		
58							7	5	3	7	6	4	58		
60										5.5	5	3	60		
62										5	4	2.5	62		
Reeving	12	14	14	10	12	13	10	10	12	10	10	10	Reeving		
Wind speed	11.1m/s			9m/s									Wind speed		
Hook	180t (deadweight 3.3t)												Hook		
Telescoping mode	I	1	2	3	1	2	3	1	2	3	2	2	3	I	Telescoping mode
	II	1	3	2	2	3	3	2	3	3	2	3	3	II	
	III	2	2	2	2	3	3	3	3	3	3	3	3	III	
	IV	3	2	2	3	2	2	3	3	3	3	3	3	IV	
	V	3	2	2	3	2	2	3	2	2	3	3	2	V	
	VI	3	2	2	3	2	1	3	2	1	3	2	2	VI	

Table 21-3 Superlift + Main boom (7 sections)



Unit: t

Main boom 34.5m – 92m, outrigger fully extended (12m x 12m), over full range, 80t counterweight Boom length \geq 62.3m, angle of superlift single edge 30° ; Boom length $<$ 62.3m, angle of superlift single edge 15°								
Radius (m)	Main boom (m)						Radius (m)	
	78.5	78.5	78.8★	84.1★	87.7★	92★		
14	94	95	102	85	75		14	
16	92	93	95	80	75	70	16	
18	82	82	82	74	72	68	18	
20	70	70	69	68	68	65	20	
22	59	59	58	59	59	59	22	
24	51	51	50	51	50	51	24	
26	44	44	43	44	45	44	26	
28	38	38	38	39	39	39	28	
30	34	33	33	34	34	34	30	
32	29	29	29	30	30	31	32	
34	28	27	26	27	28	27	34	
36	25	25	22	24.5	25	24	36	
38	23	22	21	22	22	22	38	
40	21	20	19	20	20	20	40	
42	19	18	17	18	18	18	42	
44	17	16	15	16	16	16	44	
46	15	14	13	14.5	15	14	46	
48	14	13	12	13	13	13	48	
50	12	12	10	11.8	12	11	50	
52	11	10	9	10	11	10.5	52	
54	10	9	8	9	10	9	54	
56	9	8	7	8	8.8	8	56	
58	8	7	6	7	7	7	58	
60	6	6	5	6	6	6	60	
62	5	5	4	5	5.5	5	62	
64	5	4	3	4	4.6	4	64	
66	4	3	2	3	4	3.4	66	
68	3	2.5		2.5	3	2.5	68	
70				2	2.5	2	70	
Reeving	8	8	8	8	6	6	Reeving	
Wind speed	9m/s						Wind speed	
Hook	110t (deadweight 3t)						Hook	
Telescoping mode	I	2	3	3	3	3	4	Telescoping mode
	II	3	2	3	3	3	4	
	III	3	3	3	3	3	4	
	IV	3	3	3	3	4	4	
	V	3	3	3	3	4	4	
	VI	3	3	2	3	4	4	

Table 22-1 Superlift + Main boom (7 sections)



Unit: t

Main boom 34.5m – 92m, outrigger fully extended (12m x 12m), over full range, 50t counterweight Boom length ≥ 62.3m, angle of superlift single edge 30° ; Boom length < 62.3m, angle of superlift single edge 15°														
Radius (m)	Main boom (m)												Radius (m)	
	34.2	34.5	34.5★	39.8	40	40.1★	45.1	45.4	45.6★	50.7	51.1	50.9★		
5	185	235	235										5	
5.5	175	235	235										5.5	
6	165	225	225	185	215	215							6	
7	155	205	205	175	210	210	170	185	205				7	
8	150	200	200	170	200	200	164	175	205	160	195	170	8	
9	145	188	188	165	190	190	160	170	190	155	190	160	9	
10	135	164	164	142	165	166	156	165	172	148	175	155	10	
11	122	140	140	130	145	144	125	137	150	120	145	132	11	
12	116	118	114	122	123	120	115	121	127	107	122	122	12	
14	96	94	93	99	98	97	100	100	98	92	90	92	14	
16	80	79	72	79	77	76	85	83	78	83	75	81	16	
18	64	63	57	68	65	61	70	67	63	69	61	65	18	
20	54	52	47	57	54	49	58	55	51	57	50	53	20	
22	45	43	38	48	45	41	50	47	43	49	41	45	22	
24	38	35	30	41	38	34	43	40	36	42	35	38	24	
26	32	29	25	35	33	29	37	34	31	36	29	33	26	
28	25	23.5	20	30	27	23	33	30	26	32	25	28	28	
30				26	23	19	28	26	22	28	21	24	30	
32				22	19	15	24	22	18	24	18	21	32	
34							21	19	15	21	15	18	34	
36							18	16	12	17	12	15	36	
38							16	14	10	15	10	13	38	
40										13	8	11	40	
42										12	6	9	42	
44										10	4	7	44	
Reeving	18	20	20	18	20	20	16	16	18	14	16	16	Reeving	
Wind speed	11.1m/s												Wind speed	
Hook	260t (deadweight 4.2t)												Hook	
Telescoping mode	I	1	1	2	1	1	2	1	1	2	1	3	2	I
	II	1	2	2	1	2	2	1	2	2	2	2	2	II
	III	1	2	2	2	2	2	2	2	2	2	2	2	III
	IV	2	2	1	2	2	2	2	2	2	2	2	2	IV
	V	2	1	1	2	2	1	2	2	2	2	2	2	V
	VI	2	1	1	2	1	1	3	2	1	3	1	2	VI

Table 22-2 Superlift + Main boom (7 sections)



Unit: t

Main boom 34.5m – 92m, outrigger fully extended (12m x 12m), over full range, 50t counterweight Boom length ≥ 62.3m, angle of superlift single edge 30° ; Boom length < 62.3m, angle of superlift single edge 15°															
Radius (m)	Main boom (m)												Radius (m)		
	56.2	56.5	56.5 ★	61.8	62.1	62.3 ★	67.4	67.6	67.8 ★	72.9	73.1	73.2 ★			
8	150	170	170										8		
9	145	165	165	125	140	160							9		
10	143	155	155	120	134	150	125	135	150				10		
11	120	140	140	115	130	142	120	130	140				11		
12	110	124	124	110	115	120	115	125	120	98	105	110	12		
14	94	94	94	96	96	95	96	96	95	93	95	95	14		
16	80	78	73	75	75	74	74	76	74	77	77	76	16		
18	65	64	63	60	60	60	62	60	62	63	63	60	18		
20	60	53	52	56	53	48	58	54	51	56	55	52	20		
22	51	44	43	50	45	40	49	45	43	48	46	44	22		
24	44	38	36	43	38	35	42	38	36	41	39	37	24		
26	38	32	31	37	33	30	37	33	31	35	34	32	26		
28	33	28	27	33	28	25	32	28	26	31	29	27	28		
30	30	24	23	29	24	22	28	25	22	27	26	24	30		
32	26	21	20	26	21	19	25	22	19	24	22	20	32		
34	24	18	17	23	18	16	22	19	16	21	20	18	34		
36	21	16	15	21	16	14	20	16	14	19	17	15	36		
38	19	13	12	18	14	11.5	18	14	12	17	15	13	38		
40	17	11	10	16	12	9	16	13	10	15	13	12	40		
42	14	9	8	14	10	7.5	14	11	9	13	12	10	42		
44	12	7.4	7	12	8	6	13	9	7	12	10	9	44		
46	10	6	5	10	7	4	11	8	5	10	9	7	46		
48	9	4.5	3.5	8	5	3	9.5	6	4	9	7	6	48		
50				7	4		8	5	3	8	6	4.5	50		
52				6	3		7	4		6.5	5	3	52		
54				5			5.5	3		5.5	4	2	54		
56							4.5			4	3		56		
58							3.5			3	2		58		
60													60		
Reeving	12	14	14	10	12	13	10	10	12	10	10	10	Reeving		
Wind speed	11.1m/s			9m/s									Wind speed		
Hook	180t (deadweight 3.3t)												Hook		
Telescoping mode	I	1	2	3	1	2	3	1	2	3	2	2	3	I	Telescoping mode
	II	1	3	2	2	3	3	2	3	3	2	3	3	II	
	III	2	2	2	2	3	3	3	3	3	3	3	3	III	
	IV	3	2	2	3	2	2	3	3	3	3	3	3	IV	
	V	3	2	2	3	2	2	3	2	2	3	3	2	V	
	VI	3	2	2	3	2	1	3	2	1	3	2	2	VI	

Table 22-3 Superlift + Main boom (7 sections)



Unit: t

Main boom 34.5m – 92m, outrigger fully extended (12m x 12m), over full range, 50t counterweight Boom length \geq 62.3m, angle of superlift single edge 30° ; Boom length $<$ 62.3m, angle of superlift single edge 15°										
Radius (m)	Main boom (m)						Radius (m)			
	78.5	78.5	78.8★	84.1★	87.7★	92★				
14	94	95	96	85	75		14			
16	83	78	78	75	70	70	16			
18	64	63	63	64	64	65	18			
20	54	53	54	53	53	54	20			
22	46	45	45	46	45	46	22			
24	39	39	38	39	39	39	24			
26	34	33	33	34	33	34	26			
28	29	28	28	29	29	29	28			
30	25	24	24	25	25	25	30			
32	22	21	20	21	21	21	32			
34	21	20	18	20	20	19	34			
36	18	18	16	17	18	17	36			
38	16	15	14	15	16	15	38			
40	14.5	14	12	13	14	13	40			
42	13	12	11	12	12	11	42			
44	11	10	9	10	11	10	44			
46	10	9	8	9	9	8	46			
48	9	8	7	8	8	8	48			
50	7.5	7	5.5	7	7	7	50			
52	6.4	6	4	6	6	5.5	52			
54	5.6	4.7	3.5	5	5	4.5	54			
56	4	4	2.5	4	4	4	56			
58	3	3		3	3	3	58			
60	2.5	2		1.7	2.3	2	60			
Reeving	8	8	8	8	6	6	Reeving			
Wind speed	9m/s						Wind speed			
Hook	180t (deadweight 3.3t)						Hook			
Telescoping mode	I	2	3	3	3	3	4	I	Telescoping mode	
	II	3	2	3	3	3	3	4		II
	III	3	3	3	3	3	3	4		III
	IV	3	3	3	3	3	4	4		IV
	V	3	3	3	3	3	4	4		V
	VI	3	3	2	3	3	4	4		VI

Table 23-1 Superlift + Main boom (7 sections)



Unit: t

Main boom 34.5m – 92m, outrigger fully extended (12m x 12m), over full range, 0t counterweight Boom length ≥ 62.3m, angle of superlift single edge 30° ; Boom length < 62.3m, angle of superlift single edge 15°															
Radius (m)	Main boom (m)												Radius (m)		
	34.2	34.5	34.5★	39.8	40	40.1★	45.1	45.4	45.6★	50.7	51.1	50.9★			
5	165	220	220										5		
5.5	155	210	210										5.5		
6	145	195	195	155	185	185							6		
7	135	180	180	145	175	175	160	165	170				7		
8	120	145	145	130	160	160	130	145	145	140	160	150	8		
9	112	120	120	120	122	120	110	120	120	110	130	120	9		
10	104	110	110	107	105	106	104	103	104	105	102	104	10		
11	97	95	96	101	100	99	96	94	95	84	80	82	11		
12	85	83	77	88	84	80	89	85	83	75	70	72	12		
14	65	58	54	64	61	56	67	64	59	65	57	61	14		
16	50	44	39	50	46	41	51	48	44	50	42	46	16		
18	39	34	29	39	36	31	41	38	34	40	32	36	18		
20	32	26	22	32	28	24	33	30	26	32	25	29	20		
22	25	20	16	26	23	19	28	25	21	26	19	23	22		
24	20	14	10	21	18	14	23	20	16	22	15	18	24		
26	15	10	6	17	14	10	19	17	13	18	12	15	26		
28	11	6		13	10	7	16	13	10	15	9	12	28		
30				10	7	4	13	10	7	13	6	9	30		
32				7	5		10	8	4	10	4	7	32		
34							8	6		8		5	34		
36							6	4		6			36		
38													38		
Reeving	16	20	20	16	18	18	14	16	18	14	16	14	Reeving		
Wind speed	11.1m/s												Wind speed		
Hook	260t (deadweight 4.2t)												Hook		
Telescoping mode	I	1	1	2	1	1	2	1	1	2	1	3	2	I	Telescoping mode
	II	1	2	2	1	2	2	1	2	2	2	2	2	II	
	III	1	2	2	2	2	2	2	2	2	2	2	2	III	
	IV	2	2	1	2	2	2	2	2	2	2	2	2	IV	
	V	2	1	1	2	2	1	2	2	2	2	2	2	V	
	VI	2	1	1	2	1	1	3	2	1	3	1	2	VI	

Table 23-2 Superlift + Main boom (7 sections)



Unit: t

Main boom 34.5m – 92m, outrigger fully extended (12m x 12m), over full range, 0t counterweight Boom length ≥ 62.3m, angle of superlift single edge 30° ; Boom length < 62.3m, angle of superlift single edge 15°														
Radius (m)	Main boom (m)												Radius (m)	
	56.2	56.5	56.5★	61.8	62.1	62.3★	67.4	67.6	67.8★	72.9	73.1	73.2★		
8	130	150	150										8	
9	115	125	125	125	140	135							9	
10	102	104	105	104	107	106	95	106	108				10	
11	88	85	85	88	86	85	88	86	83				11	
12	78	71	72	74	72	68	73	71	69	75	72	70	12	
14	64	55	55	53	50	52	55	53	50	54	52	50	14	
16	50	45	44	40	39	37	42	42	42	42	40	40	16	
18	40	35	34	31	29	28	32	32	31	32	30	30	18	
20	32	28	27	29	27	25	30	29	26	29	27	25	20	
22	26	22	21	25	22	20	25	23	20	25	23	22	22	
24	22	18	17	21	18	15	21	19	16	21	20	18	24	
26	20	14	13	18	15	12	18	15	13	18	16	14	26	
28	17	12	11	15	12	9	15	12	10	14	13	11	28	
30	15	9	8	13	9	7	13	10	7	12	11	9	30	
32	13	7	6	11	7	5	11	8	5	10	9	7	32	
34	11	5	4	9	6	3	9	6	4	8	7	5	34	
36	9	3		7	4		7	5		7	6	4	36	
38	7			6			6			6	4		38	
Reeving	12	14	14	10	12	12	10	10	12	10	10	10	Reeving	
Wind speed	11.1m/s			9m/s									Wind speed	
Hook	180t (deadweight 3.3t)												Hook	
Telescoping mode	I	1	2	3	1	2	3	1	2	3	2	2	3	I
	II	1	3	2	2	3	3	2	3	3	2	3	3	II
	III	2	2	2	2	3	3	3	3	3	3	3	3	III
	IV	3	2	2	3	2	2	3	3	3	3	3	3	IV
	V	3	2	2	3	2	2	3	2	2	3	3	2	V
	VI	3	2	2	3	2	1	3	2	1	3	2	2	VI

Table 23-3 Superlift + Main boom (7 sections)



Unit: t

Main boom 34.5m – 92m, outrigger fully extended (12m x 12m), over full range, 0t counterweight Boom length \geq 62.3m, angle of superlift single edge 30° ; Boom length < 62.3m, angle of superlift single edge 15°										
Radius (m)	Main boom (m)						Radius (m)			
	78.5	78.5	78.8★	84.1★	87.7★	92★				
14	56	55	54	58	58		14			
16	42	42	42	45	44	45	16			
18	35	35	34	35	34	35	18			
20	28	27	28	28	27	28	20			
22	22	21	22	22	22	22	22			
24	18	18	18	18	18	18	24			
26	17	16	15	15	14	13	26			
28	14	13	12	12	11	11	28			
30	12	11	10	9	8	8	30			
32	10	9	8	7	7	7	32			
34	8	7	6	6	7	6	34			
36	6	6	4	5	6	5	36			
38	5	4		4	4.5	4	38			
40							40			
Reeving	8	8	8	8	6	6	Reeving			
Wind speed	9m/s						Wind speed			
Hook	110t (deadweight 3t)						Hook			
Telescoping mode	I	2	3	3	3	3	4	I	Telescoping mode	
	II	3	2	3	3	3	3	4		II
	III	3	3	3	3	3	3	4		III
	IV	3	3	3	3	3	4	4		IV
	V	3	3	3	3	3	4	4		V
	VI	3	3	2	3	3	4	4		VI

Table 24-1 Superlift + Main boom (7 sections)



Unit: t

Main boom 34.5m – 92m, outrigger intermediately extended, over full range, 0t counterweight Boom length \geq 62.3m, angle of superlift single edge 30° ; Boom length $<$ 62.3m, angle of superlift single edge 15°														
Radius (m)	Main boom (m)												Radius (m)	
	34.2	34.5	34.5★	39.8	40	40.1★	45.1	45.4	45.6★	50.7	51.1	50.9★		
5	145	185	185										5	
5.5	140	175	175										5.5	
6	130	170	170	155	185	185							6	
7	125	145	145	145	175	175	125	135	150				7	
8	107	109	106	115	112	109	110	112	110	110	105	108	8	
9	81	80	80	89	87	85	94	92	89	85	80	83	9	
10	67	66	65	72	70	68	75	73	70	70	65	68	10	
11	54	52	52	56	54	53	62	60	58	58	55	56	11	
12	43	42	40	46	45	43	53	51	49	48	45	46	12	
14	30	28	27	32	30	30	38	36	35	34	31	33	14	
16	20	18	18	23	23	21	28	27	25	24	21	22	16	
18	12	11	10	15	15	13	20	18	18	17	15	16	18	
20	7	7	6	10	10	8	15	14	13	12	10	11	20	
22				7	6	6	11	10	10	8	7	7	22	
24							9	8	8	6	6	6	24	
26										5		5	26	
Reeving	14	16	16	14	16	16	12	12	14	10	10	10	Reeving	
Wind speed	11.1m/s												Wind speed	
Hook	180t (deadweight 3.3t)												Hook	
Telescoping mode	I	1	1	2	1	1	2	1	1	2	1	3	2	I
	II	1	2	2	1	2	2	1	2	2	2	2	2	II
	III	1	2	2	2	2	2	2	2	2	2	2	2	III
	IV	2	2	1	2	2	2	2	2	2	2	2	2	IV
	V	2	1	1	2	2	1	2	2	2	2	2	2	V
	VI	2	1	1	2	1	1	3	2	1	3	1	2	VI

Table 24-2 Superlift + Main boom (7 sections)



Unit: t

Main boom 34.5m – 92m, outrigger intermediately extended, over full range, 0t counterweight Boom length \geq 62.3m, angle of superlift single edge 30° ; Boom length $<$ 62.3m, angle of superlift single edge 15°														
Radius (m)	Main boom (m)												Radius (m)	
	56.2	56.5	56.5★	61.8	62.1	62.3★	67.4	67.6	67.8★	72.9	73.1	73.2★		
8	106	110	110										8	
9	87	85	83	90	88	85							9	
10	71	68	66	73	71	70	74	72	70				10	
11	59	54	53	61	60	59	62	60	58				11	
12	49	46	45	51	50	48	52	50	50	52	50	48	12	
14	36	34	32	37	35	35	38	36	35	37	35	34	14	
16	26	25	23	26	25	25	28	27	26	29	28	27	16	
18	18	16	16	20	20	19	21	20	20	22	21	20	18	
20	14	12	12	14	13	12	15	14	14	16	15	15	20	
22	11	10	9	11	10	10	11	10	10	12	11	10	22	
24	9	8	7	10	9	8	9	8	8	10	9	8	24	
26	8	7	6	9	8	6	8	7	6	8	7	7	26	
28				8	6		7	6	5	6	5	5	28	
30										5	4	4	30	
Reeving	10	10	10	8	8	8	6	6	6	4	4	4	Reeving	
Wind speed	11.1m/s			9m/s									Wind speed	
Hook	180t (deadweight 3.3t)												Hook	
Telescoping mode	I	1	2	3	1	2	3	1	2	3	2	2	3	I
	II	1	3	2	2	3	3	2	3	3	2	3	3	II
	III	2	2	2	2	3	3	3	3	3	3	3	3	III
	IV	3	2	2	3	2	2	3	3	3	3	3	3	IV
	V	3	2	2	3	2	2	3	2	2	3	3	2	V
	VI	3	2	2	3	2	1	3	2	1	3	2	2	VI

Table 24-3 Superlift + Main boom (7 sections)



Unit: t

Main boom 34.5m – 92m, outrigger intermediately extended, over full range, 0t counterweight Boom length \geq 62.3m, angle of superlift single edge 30° ; Boom length $<$ 62.3m, angle of superlift single edge 15°									
Radius (m)	Main boom (m)						Radius (m)		
	78.5	78.5	78.8★	84.1★	87.7★	92★			
14	40	40	38	38	40				14
16	30	29	29	30	30	30			16
18	23	22	22	23	22	22	22		18
20	17	16	15	18	18	18			20
22	14	13	12	14	14	14			22
24	10	9	8	11	11	11			24
26	9	8	7	9	9	9			26
28	7	6	5	7	7	7			28
30	5	4	4	5	6	5			30
34									34
Reeving	4	4	4	4	4	2			Reeving
Wind speed	9m/s								Wind speed
Hook	50t (deadweight 1.9t)								Hook
Telescoping mode	I	2	3	3	3	3	4	I	Telescoping mode
	II	3	2	3	3	3	4	II	
	III	3	3	3	3	3	4	III	
	IV	3	3	3	3	4	4	IV	
	V	3	3	3	3	4	4	V	
	VI	3	3	2	3	4	4	VI	

Lifting capacity tables / Lifting height charts

7-section main boom + superlift + 33m wind plant tip boom OM

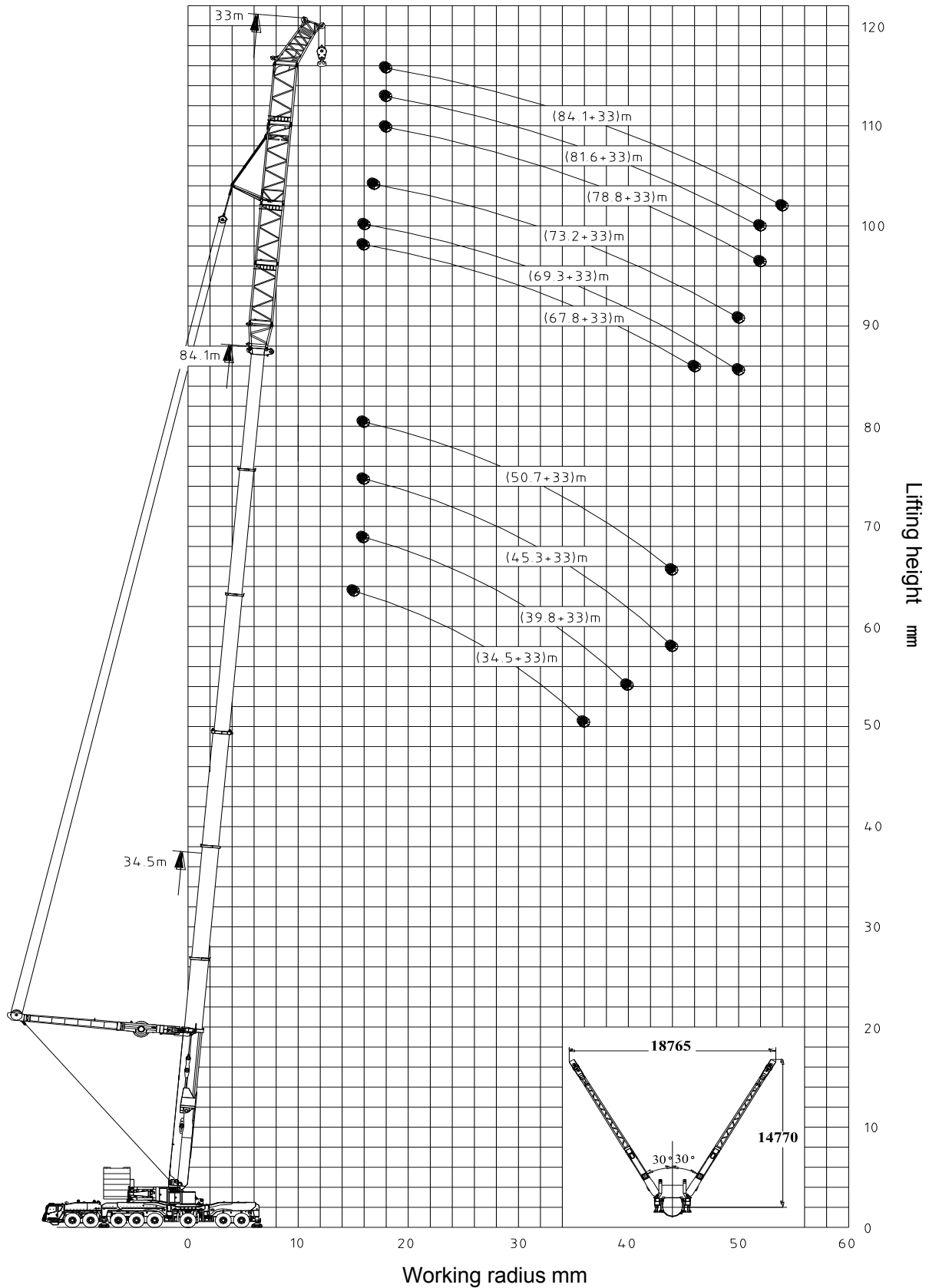

Table 25 Wind turbine installation OM



Unit: t

33m wind plant tip boom, outrigger fully extended (12m x12m), over full range, 135t counterweight, angle of superlift single edge 30°													
Radius (m)	Main boom (m) + 33 m Wind plant tip boom										Radius (m)		
	34.5	39.8	45.3	50.7	67.8	69.3	73.2	78.8	81.6 ▲	84.1 ▲			
15	80											15	
16	75	85	90	105	104	100						16	
17	72	80	86	103	102	98	100					17	
18	70	75	77	101	100	95	96	85	78	70		18	
19	67	72	74	97	98	95	95	85	75	70		19	
20	64	68	70	95	95	93	95	83	75	68		20	
21	61	65	66	92	95	92	93	82	72	68		21	
22	58	61	62	88	92	90	90	76	70	65		22	
24	55	57	57	84	90	87	86	72	64	57		24	
26	51	53	53	76	83	75	75	64	57	52		26	
28	47	50	50	72	70	65	63	55	53	48		28	
30	44	47	47	65	61	55	55	46	44	43		30	
32	39	45	45	58	56	50	50	41	39	38		32	
34	35	42	42	53	50	47	47	38	36	35		34	
36	32	40	40	47	45	43	43	33	32	31		36	
38		38	38	42	38	35	35	29	29	28		38	
40		35	35	36	35	33	32	27	26	25		40	
42			32	31	30	30	30	25	23	21		42	
44				26	27	27	27	21	20	18		44	
46					22	24	25	19	18	16		46	
48						22	22	17	16	15		48	
50						20	19	16	15	14		50	
52								15	14	13		52	
54										12		54	
Reeving	8	8	8	9	8	8	8	7	6	6		Reeving	
Wind speed	9m/s										Wind speed		
Hook	110t (deadweight 3t)										Hook		
Telescoping mode	I	1	1	1	1	3	4	3	3	4	3	I	Telescoping mode
	II	1	1	1	1	3	3	3	3	4	3	II	
	III	1	1	1	1	3	3	3	3	3	3	III	
	IV	3	3	3	3	3	3	3	3	3	3	IV	
	V	2	2	3	3	2	2	2	3	3	3	V	
	VI	1	2	2	3	1	1	2	2	2	3	VI	

Note:

As for OM marked with the triangle (▲), 6m superlift anchoring rods should be connected.

Lifting capacity tables / Lifting height charts

7-section main boom + superlift + 27m wind plant tip boom OM

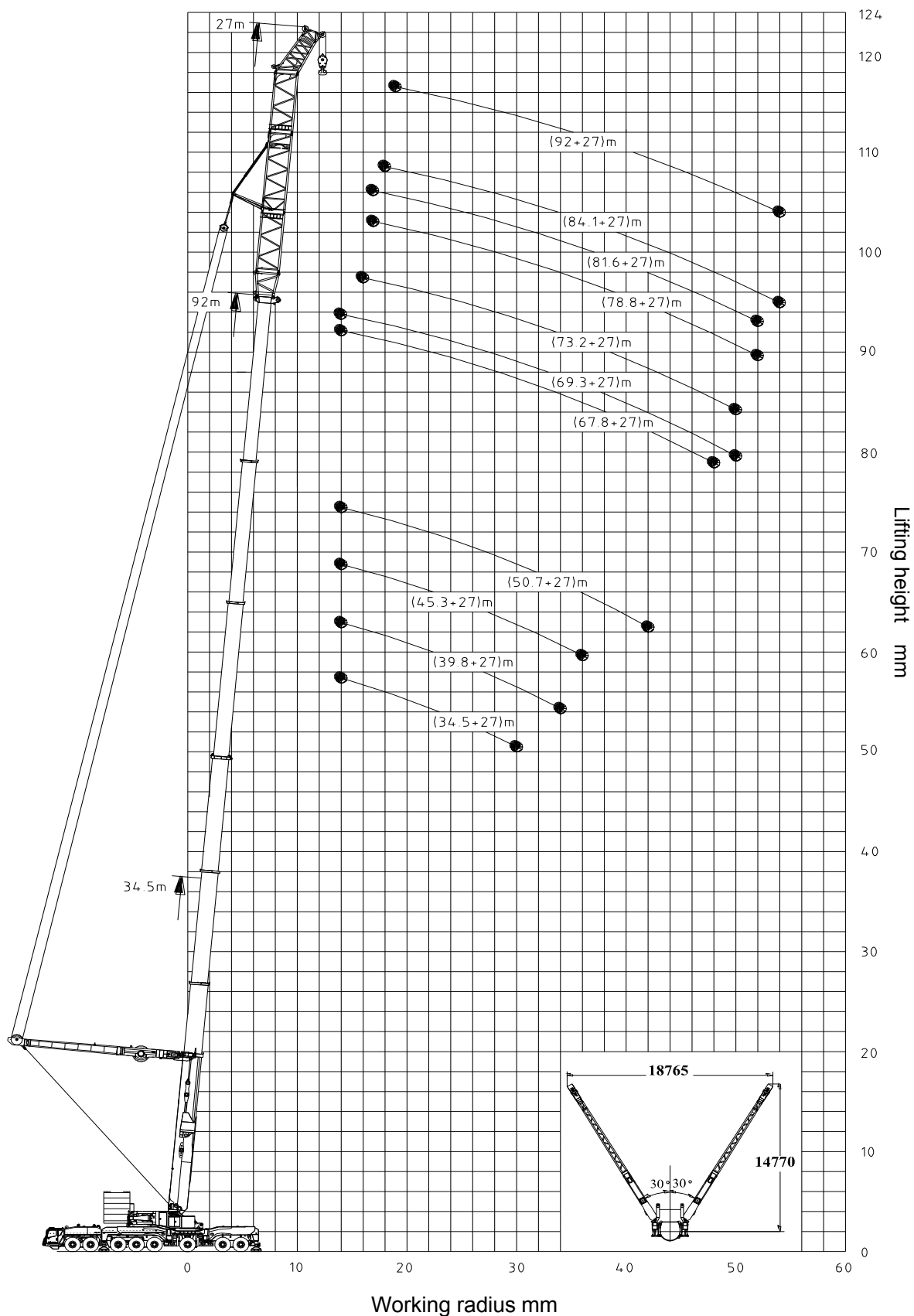

Table 26 Wind turbine installation OM



Unit: t

27m wind plant tip boom, outrigger fully extended (12m x12m), over full range, 135t counterweight, angle of superlift single edge 30°													
Radius (m)	Main boom (m) + 27 m Wind plant tip boom											Radius (m)	
	34.5	39.8	45.3	50.7	67.8	69.3	73.2	78.8	81.6	84.1	92 ▲		
14	85	90	95	106	105	102							14
15	85	90	95	106	105	102							15
16	79	90	95	102	104	102	102						16
17	75	86	90	97	103	102	102	92	82				17
18	72	82	86	95	102	100	100	88	80	75			18
19	70	77	82	86	100	100	98	86	76	72	62		19
20	68	75	78	80	98	97	98	85	73	68	61		20
21	66	72	75	76	95	94	95	82	71	64	60		21
22	63	68	71	72	90	88	86	79	70	61	57		22
24	61	63	68	70	84	81	79	74	68	58	53		24
26	60	59	62	67	72	70	68	70	65	54	50		26
28	56	54	59	63	65	63	61	61	57	50	47		28
30	52	53	52	56	58	57	55	53	50	46	42		30
32		51	51	52	53	53	47	44	42	41	39		32
34		48	50	50	50	50	42	40	37	34	32		34
36			45	45	48	48	38	36	34	31	28		36
38			36	41	41	41	34	32	30	28	25		38
40				32	33	35	28	27	24	24	21		40
42				29	30	31	25	23	21	19	17		42
44				26	27	28	22	21	19	18	16		44
46					25	26	20	20	18	16	15		46
48					22	24	19	19	17	15	14		48
50						20	18	18	16	14	13		50
52								17	15	13	12		52
54										12	11		54
Reeving	8	8	8	9	8	8	8	7	7	6	6		Reeving
Wind speed	9m/s											Wind speed	
Hook	110t (deadweight 3t)											Hook	
Telescoping mode	I	1	1	1	1	3	4	3	3	4	3	4	I
	II	1	1	1	1	3	3	3	3	4	3	4	II
	III	1	1	1	1	3	3	3	3	3	3	4	III
	IV	3	3	3	3	3	3	3	3	3	3	4	IV
	V	2	2	3	3	2	2	2	3	3	3	4	V
	VI	1	2	2	3	1	1	2	2	2	3	4	VI

Note:

As for OM marked with the triangle (▲), 6m superlift anchoring rods should be connected.

Lifting capacity tables / Lifting height charts

7-section main boom + superlift + 21m wind plant tip boom OM

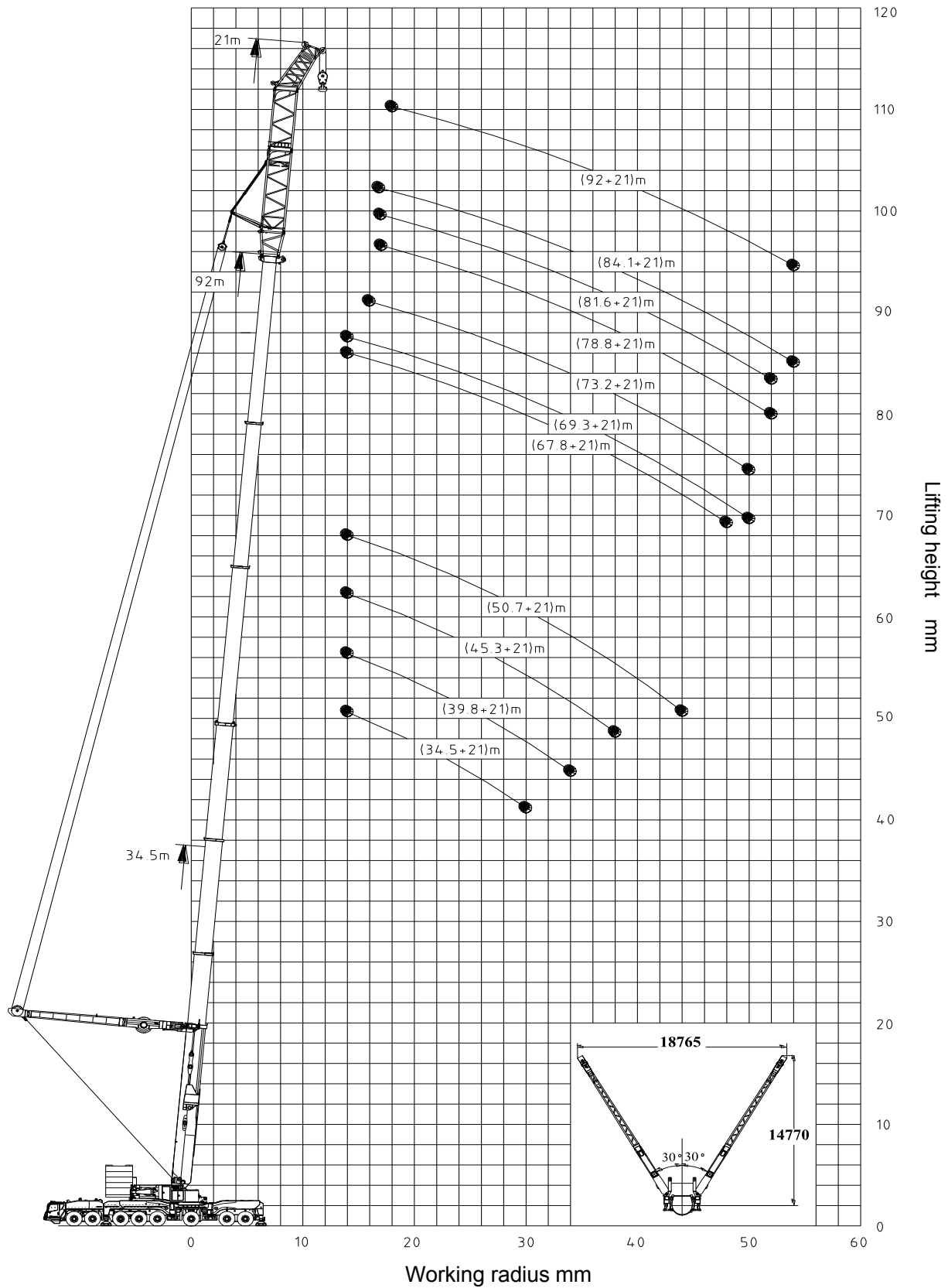

Table 27 Wind turbine inspection and maintenance OM



Unit: t

21m wind plant tip boom, outrigger fully extended (12m x12m), over full range, 115t counterweight, angle of superlift single edge 30°													
Radius (m)	Main boom (m) + 21 m Wind plant tip boom											Radius (m)	
	34.5	39.8	45.3	50.7	67.8	69.3	73.2	78.8	81.6	84.1	92		
14	90	95	100	110	106	105							14
15	90	95	100	110	106	105							15
16	86	93	95	106	104	103	105						16
17	80	89	92	103	103	102	105	95	85	82			17
18	77	85	90	98	100	100	102	92	85	82	68		18
19	75	80	89	94	98	98	102	90	83	82	68		19
20	73	78	87	90	95	97	98	88	82	80	65		20
21	70	76	85	86	93	95	96	85	81	78	63		21
22	69	70	81	81	90	92	91	81	79	76	62		22
24	66	66	77	75	85	85	85	77	77	72	57		24
26	62	61	72	70	80	81	81	73	74	66	53		26
28	60	58	68	66	72	70	70	68	67	61	49		28
30	57	56	65	62	71	65	67	65	63	57	44		30
32		55	59	57	65	63	62	57	55	53	41		32
34		51	55	53	61	58	56	50	49	45	35		34
36			49	47	53	52	47	47	43	41	31		36
38			39	43	46	46	44	42	40	34	28		38
40				36	43	42	41	36	35	30	23		40
42				32	38	37	36	31	31	25	19		42
44				29	32	32	30	27	26	20	17		44
46					27	26	25	23	22	18	16		46
48					25	23	22	21	19	17	15		48
50						22	20	19	18	16	14		50
52								18	17	15	13		52
54										14	12		54
Reeving	8	8	8	9	9	8	8	7	6	6	6		Reeving
Wind speed	9m/s											Wind speed	
Hook	110t (deadweight 3t)											Hook	
Telescoping mode	I	1	1	1	1	3	4	3	3	4	3	4	I
	II	1	1	1	1	3	3	3	3	4	3	4	II
	III	1	1	1	1	3	3	3	3	3	3	4	III
	IV	3	3	3	3	3	3	3	3	3	3	4	IV
	V	2	2	3	3	2	2	2	3	3	3	4	V
	VI	1	2	2	3	1	1	2	2	2	3	4	VI

Components, superstructure

Main boom

- 7-section telescopic boom made of 1100MPa high-tensile steel;
- Optimal oviform boom profile of particular tensional rigidity, outstanding local stability and for the super lifting capacities;
- Main boom is not attached with the vehicle during normal driving. It is transported by a trailer. Assembly and dismantle main boom with the help of the crane before lifting operation.
- There are two operating modes, namely 4-section and 7-section main boom.
- During short-distance travelling, one of the following items can be attached with the vehicle:
 - 2-section main boom
 - 4-section main boom
 - 7-section main boom, superlift device and counterweight carrier.

Wind plant tip boom

- Wind plant tip boom variants: 21m, 27m, 33m;
- Eccentric A-frame as well as widened and heightened superlift hinge;
- It is not attached with the vehicle during traveling.

Telescoping system

- The telescopic boom is telescoped by the single-stage telescoping cylinder with hydraulic interlocking device and double side pins;
- Rapid-cycle telescoping system with “automatic mode”, i.e. all-automatic telescoping to the desired boom length in sequence;
- Telescoping procedure is automatically or manually controllable by convenient operator guide on the monitor.

Y-shaped guying system

- Y-shaped guying system with equal rope length and in single sheet structure.
- It is assembled on the head of boom 85 and adopts 2 reeving wire rope.
- It can be properly assembled with the help of the auxiliary crane.

Hoist gear

- The reducer, drum, brake and motor integrated hoist gear is of high quality and is compact in structure;
- A special type of sheave groove ensures optimum spooling behavior of 10-layer wire rope and perfect rope arrangement during multiple-layer spooling, thus providing prolonged rope service life;
- Imported high-performance rotation-resistant ropes can be used without swivel under load and can be arranged orderly on the drum; the press nipple can be used for rapid reeving change.

Luffing gear

- Two hydraulic cylinders, providing the boom with smooth luffing movements from -0.4° to 86°

Slewing gear

- Two slewing gears, consisting of hydraulic motor and planetary reducer
- Slewing speed: 0 – 0.8 rpm

Slewing table

- Box-type, torsion resistant design of high-tensile steel, providing super load bearing capacity

Operator's cab

- 4.0 series spacious panoramic cab with sliding door, outward pushing windshield, front foot pedal, safe guard rail around the roof and side of the cab
- No instrument console and electric elements are in the front of the cab. And thus, you can have a good riding experience due to spacious room and comfortable feeling.
- Integrated bus key panel is compact, simple and reliable. Night vision background light is clear and make light work safe.
- Vertical 12 inch two-in-one LCD (touch screen) integrates all of functions and has good observation angle. And thus, you can have good operation experience.
- USB interface is chargeable.
- Rear swing operator's cab movement mechanism can realize bipolar swing, raise/lower, tilt forwards and backwards movements etc. The operator's cab is swung to the rear end of slewing table and fixed well under the transport condition.
- Cab heater and air conditioning.

Engine

- 6-cylinder in-line diesel, manufactured by Benz, model OM926LA, turbo-charged, intercooled
- Performance: 240 KW at 2200 rpm
- Maximum torque: 1300 Nm at 1200 – 1600 rpm
- Noise absorption and low emissions (exhaust emissions according to Off-road National Stage III Emission Standard), safe and environment-friendly;
- Fuel tank capacity: 370L.

Counterweight

- 195 t total counterweight (including 12t counterweight carrier) among which 183t movable counterweight, bottom counterweight (15t per piece) and side counterweight (10t per piece)
- Counterweight combinations include 195 t, 155 t, 135 t, 115 t, 95 t, 80 t, 50 t and 0 t.
- 135t standard configuration and 195t full configuration.

Hook

- Hook: 350t, 260t, 180t, 110t, 50t, 27t, 12t.
- As for the hooks are equal to or more than 110t, they are ramshorn ones.
- 110t hook, standard configuration, is special for wind plant OM.

Hood

- In frame-type structure of high functionality and convincing design

Central lubricating system

- All the lubricating points are automatically supplied with the correct grease quantity for prolonged crane service life and easy maintenance.

Control system

- Superstructure hydraulic system adopts open and closed combined system. Main winch and slewing gear adopt the closed system. Luffing gear and telescoping system adopt the open system. Other auxiliary mechanism adopts the valve control system.
- Germany Linde hydraulic pump, motor and Bucher big flow proportional control valve block greatly improve the operation reliability and the inching performance.
- Control mode plus closed winch safe control strategy, the third generation superlift rope length automatic compensation control strategy, simultaneous crane movements loading strategy, the operational stability and smoothness control strategy of main movements.

Monitoring system

- Field-proven Hirschmann load moment limiter in high precision and for enhanced safety and reliability;
- Via the CAN data bus system, support forces and chassis frame lateral inclination with indicators on the chassis and on the load moment limiter monitor in the operator's cab for enhanced safety;
- Field-proven remote controller realizes full range operation. Most of the superstructure movements are controllable by the remote controller. Convenient interactive functions permit the display of safety information, e.g. load moment, hook height, engine fault and warning signals "Main / auxiliary winch approaching upper / lower limit" etc. on the load moment limiter monitor during crane operation, thus to ensure safe and operator-friendly operation.

Components, chassis

Engine

- Model: Benz OM502LA.E3B/1 series
- Type: V-type, 8-cylinder diesel with 4 stroke cycles, turbo-charged, intercooled
- Displacement: 15.93 L
- Rated power: 480 kw at 1800 r/min
- Max. output torque: 3000 N.m at 1300 r/min
- Limits for exhaust pollutants and smoke: conforming to National Stage V
- Fuel tank capacity: 600L.

Transmission

- ZF transmission system AMT with automatic switching system, torque converter and hydraulic retarder;
- It is imported from Germany.
- 12 forward and 2 reverse speeds

Transfer case

- Kessler 2-stage transfer case, with stand-by steering pump
- It is imported from Germany.

Axles

- Kessler axle imported from Germany
- With disc brakes
- Axle load: 12 t
- Drive type: 16 × 12
- All axles are steered. Axles 1, 2, 4 and 5 are mechanical drive.
- Axle 8 is hydraulic drive.
- Axles 1, 2, 4 and 5 are with transversal differentials and differential locks
- Axles 2 and 4 are with longitudinal differential and differential lock.

Outrigger

- X type two sectional outrigger
- Vertical cylinders with two-way hydraulic locks
- Outriggers can be controlled by an independent wireless small remote controller. Besides, it is equipped with a wire emergency control box.
- The outrigger reaction can be shown and detected on the interface of load moment limiter in operator's cab in real time. Therefore, this guarantees the safe operation.
- Front and rear outriggers can be assembled and dismantled quickly. Rear outriggers are not attached with the vehicle under the bulletin condition.

Tires

- Tubeless tire
- Tire size: 445/95 R25 radial tires
- Tire pressure: 0.9 MPa

Steering system

- Electrical control all-wheel steer with 6 steering programs
- Wired emergency control box
- 4 front axles are mechanical steer and 4 rear axles are electro-hydraulic servo steer.
- Double-channel steering gear and single axle double-cylinder booster.
- Centralizing cylinders on all of electrical control steering axles for automatic straightening of axles in case of failure

Suspension

- All axles with hydro-pneumatic suspension and automatic leveling system
- It is also of rigid locking heavy load driving function.
- The axles are hydro-pneumatically sprung via hydraulic cylinders and are hydraulically lockable. Entire vehicle can be raised or lowered and its left / right side can also be raised or lowered independently. All axles can be raised or lowered after the crane is supported on outriggers.
- The synchronized extension and retraction movements of suspension cylinders can be realized by the speed control valve fitted in the oil line of main valve.

Brake system

- It consists of service brake, parking brake (emergency brake) and auxiliary brake.
- Service brake: dual-circuit air brake system, acting on 16 disc brakes
- Parking brake (Emergency brake): spring-loaded brake, acting on 10 disc brakes
- Auxiliary brake: consisting of engine retarder (compression release engine brake & engine exhaust brake) and transmission hydraulic retarder
- The engine retarder is used for long descending gradients to minimize wear of disc brake. The transmission hydraulic retarder is used to minimize wear of disc brake during normal driving condition.
- The brake system is with ABS.

Electrical system

- CAN data bus technology
- The driver's cab is equipped with a large multifunctional electronic display screen (touch screen) in multiple interfaces with convenient interactive functions.
- Generator: 28 V, 100 A
- 4 travelling modes (controlled by rotary switches): high speed, city, half of boom, full boom (heavy load)
- One-button activate the hydraulic drive function. Hydraulic drive and traveling modes as well as speed limit function have their own control lights.
- Bus arrangement, visual monitor and interface display help to check and clear the faults.
- Click the system warning light to skip to the detection interface directly.
- Suspension commissioning interface detects and monitors the energized and deenergized condition of all of corresponding valves in a whole process. And thus, the operation becomes simple and visualized.

Driver's cab

- 4.0 series full-width and all-metal welded spacious cab with flexible lining is of convincing design and outstanding functionality
- The cab is with the following features:
 - Height and inclination adjustable steering wheel
 - Electric windows, windshield wiper & washing device and large combined multi-angle reflectors
 - 3 comfortable seats with armrests and seat belts. (The pneumatically suspended driver's seat can be adjusted automatically to suit any driver height and size.)
 - Luxurious instrument console equipped with multifunctional electronic instrument, control lights, control switches, cigarette lighter, USB interface and MP3 player and so on
 - Adjustable cab heater / defroster and air conditioning
- Semi-floating driver's cab suspension