

# 85 ton capacity ZCC850V



**ZOOMLION**

**4.0**  
PRODUCTS

**ZOOMLION**

**Zoomlion Heavy Industry Science & Technology Co.,Ltd.**  
Add: No.677, Lugu Road, Zoomlion Industrial Park, Changsha, Hunan, China, 410205  
Copyright©2019 Zoomlion. All rights reserved. Reproduction and copying of any part of contents is not allowed for any purposes without Zoomlion's approval.



Product specifications are subject to change without notice and obligation. The photographs and/or drawing in this document are for illustrative purposes only. Please consult your local ZOOMLION dealer for more information.  
website:en.zoomlion.com 2020.04.16

VISION CREATES FUTURE

## CONTENTS

ZCC850V	DIMENSIONS	01
ZCC850V	TECHNICAL FEATURE	01
ZCC850V	BOOM COMBINATION	02
ZCC850V	TRANSPORT DIMENSIONS AND WEIGHTS	03 / 06
ZCC850V	TECHNICAL DESCRIPTION	07 / 08
ZCC850V	LIFTING PERFORMANCE	09 / 12



## DIMENSIONS

Basic machine with undercarriage

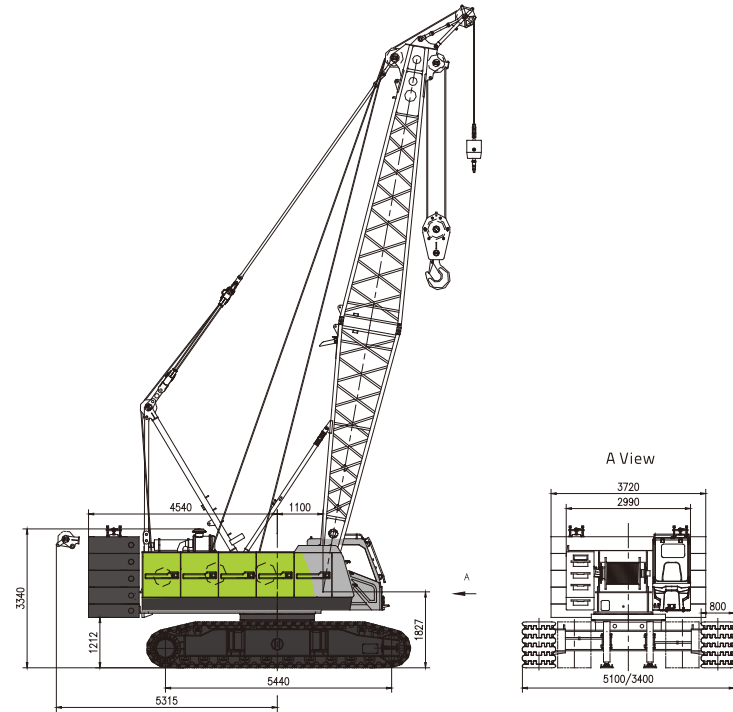

### Operating weight

The operating weight includes the basic machine with crawlers, 2 main winches including wire ropes (230m and 150m) and 13m main boom, consisting of FA-frame, boom foot (6.5m), boom head(6.5m), 28.5 t rear counterweight and 85t hook block.

Total weight ----- approx.75.5t

### Equipment

Main boom Max. Length ----- 61m

Fixed jib ----- 7-19m

Max. combination ----- main boom 49m

----- fixed jib 19m

Max. lifting moment ----- 357t.m

Max. lifting capacity on fixed jib ----- 15t

## TECHNICAL FEATURE

### High working efficiency

- Single rope speed of H1 and H2 reaches 140m/min (the 3rd layer).
- The optional free-fall winch helps to improve the efficiency of hoisting.

### Optimization in transport and dismantling

- Tracks are extendible and retractable. Max. width of whole machine in transportation is 3.4m, the width can reduce to less 3m after dismantling the tracks.
- The weight of a single counterweight plate shall not exceed 6.0t. A small auxiliary crane can help to finish the assembly.
- Optional vertical outriggers are convenient for the assembly and dismantling of track carrier.

## BOOM COMBINATION

Code	Operating mode	Boom combination
S	Main boom	13m - 61m
SH-1	Main boom + tip boom (primary hook)	13m - 58m
SH-2	Main boom + tip boom (auxiliary hook)	13m - 58m
SF-1	Main boom + fixed jib (auxiliary hook, without primary hook)	(28m - 49m) + (7m - 19m)
SF-2	Main boom + fixed jib (auxiliary hook, with primary hook)	(28m - 49m) + (7m - 19m)
SF-3	Main boom + fixed jib (primary hook)	(28m - 49m) + (7m - 19m)

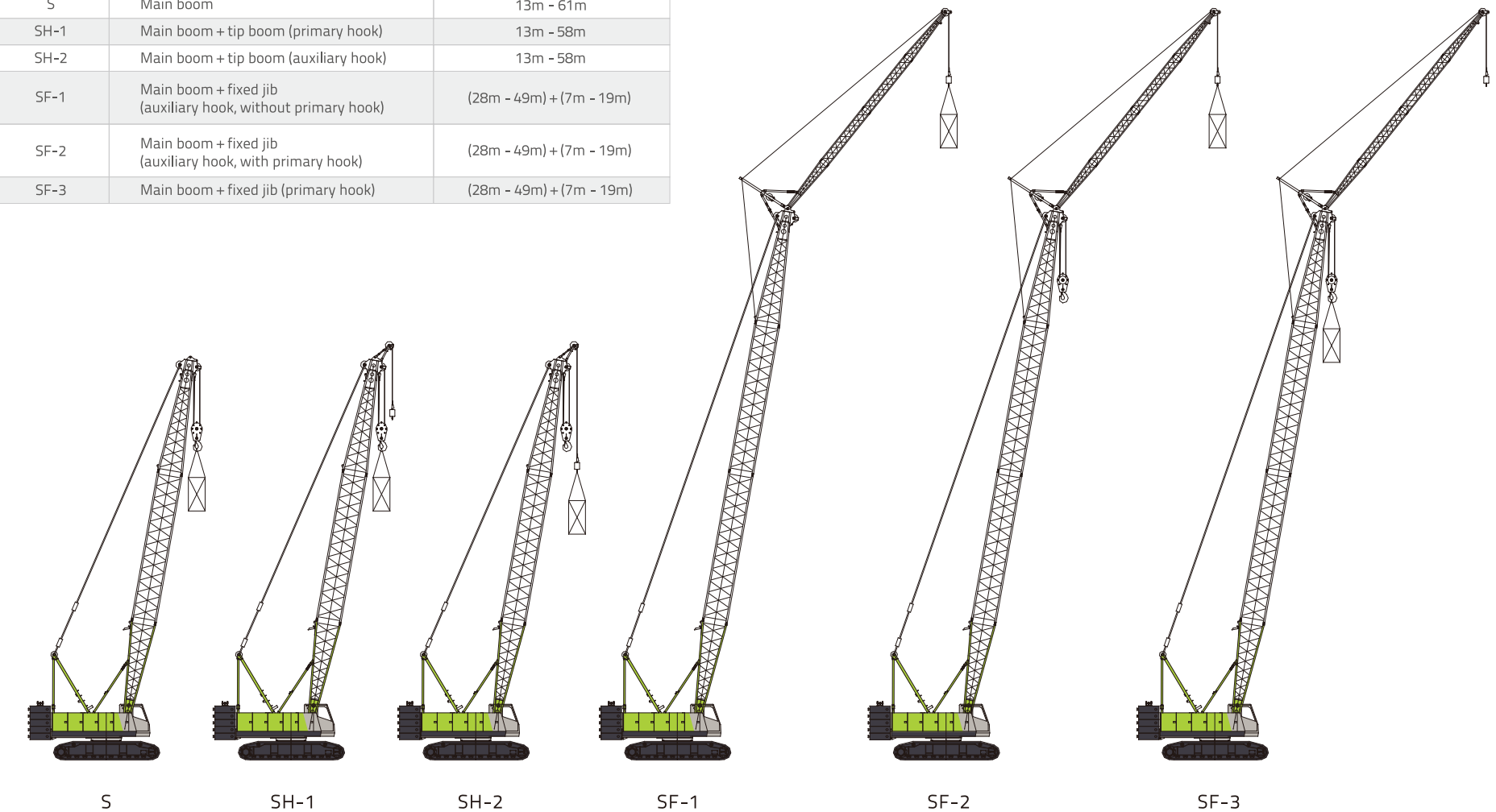



## TRANSPORT DIMENSIONS AND WEIGHTS

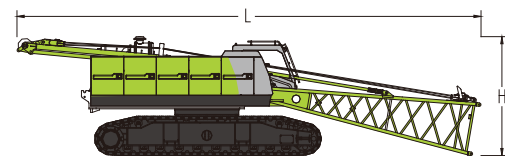

<b>Basic machine 1 (with pivot section and tracks on)</b>	<b>1 piece*</b>
Length (L)	13000 mm
Width (W)	3400 mm
Height (H)	3340 mm
Weight	39400 kg

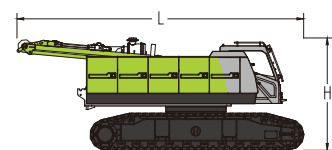

<b>Basic machine 2 (with tracks on)</b>	<b>1 piece*</b>
Length (L)	8230 mm
Width (W)	3400 mm
Height (H)	3340 mm
Weight	38330 kg

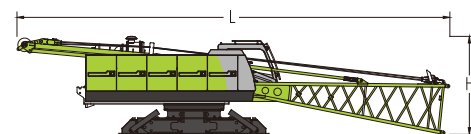

<b>Basic machine 3 (with pivot section on)</b>	<b>1 piece*</b>
Length (L)	13000 mm
Width (W)	2990 mm
Height (H)	2940 mm
Weight	22720 kg
	Outriggers are optional

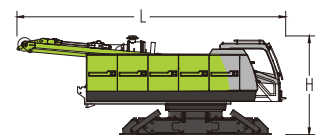

<b>Basic machine 4</b>	<b>1 piece*</b>
Length (L)	8000 mm
Width (W)	2990 mm
Height (H)	2940 mm
Weight	21650 kg
	Outriggers are optional



<b>Track carrier assy</b>	<b>2 pieces*</b>
Length (L)	6340 mm
Width (W)	1040 mm
Height (H)	1120 mm
Weight	8340 kg

## TRANSPORT DIMENSIONS AND WEIGHTS

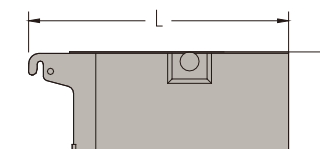

<b>Central counterweight</b>	<b>2 pieces</b>
Length (L)	3720 mm
Width (W)	1320 mm
Height (H)	685 mm
Weight	2500 kg

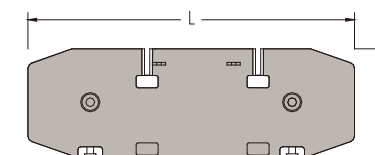

<b>Counterweight base</b>	<b>1 pieces</b>
Length (L)	3720 mm
Width (W)	1220 mm
Height (H)	650 mm
Weight	4500 kg

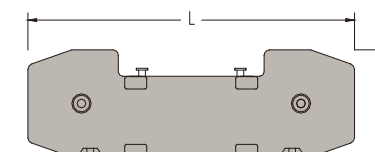

<b>Counterweight plate</b>	<b>4 pieces</b>
Length (L)	3720 mm
Width (W)	1220 mm
Height (H)	450 mm
Weight	6000 kg

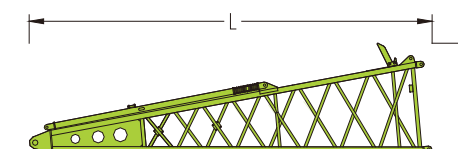

<b>Main boom pivot section</b>	<b>1 piece*</b>
Length (L)	6700 mm
Width (W)	1690 mm
Height (H)	1800 mm
Weight	1070 kg

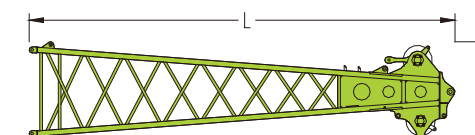

<b>Main boom head</b>	<b>1 piece</b>
Length (L)	7130 mm
Width (W)	1690 mm
Height (H)	1630 mm
Weight	1140 kg

## TRANSPORT DIMENSIONS AND WEIGHTS

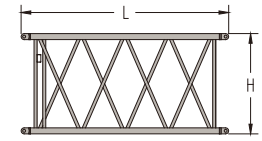

Main boom intermediate section of 3m		2 pieces*
Length (L)	3090 mm	
Width (W)	1690 mm	
Height (H)	1500 mm	
Weight	260 kg	

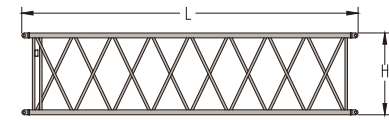

Main boom intermediate section of 6m		1 piece*
Length (L)	6090 mm	
Width (W)	1690 mm	
Height (H)	1500 mm	
Weight	440 kg	

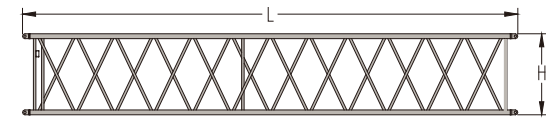

Main boom intermediate section of 9m		4 pieces*
Length (L)	9090 mm	
Width (W)	1690 mm	
Height (H)	1500 mm	
Weight	640 kg	

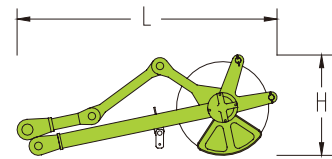

Tip boom		1 piece
Length (L)	1390 mm	
Width (W)	590 mm	
Height (H)	540 mm	
Weight	130 kg	

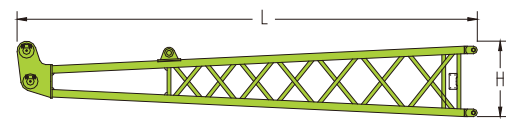

Fixed jib pivot section		1 piece*
Length (L)	3640 mm	
Width (W)	570 mm	
Height (H)	570 mm	
Weight	165 kg	

## TRANSPORT DIMENSIONS AND WEIGHTS

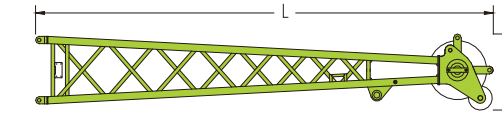

Fixed jib head		1 piece*
Length (L)	3820 mm	
Width (W)	570 mm	
Height (H)	570 mm	
Weight	220 kg	

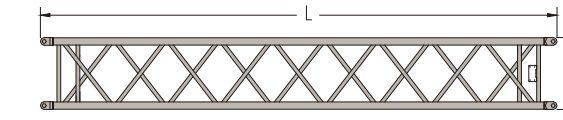

Fixed jib intermediate section of 4m		3 pieces*
Length (L)	4060 mm	
Width (W)	570 mm	
Height (H)	570 mm	
Weight	120 kg	

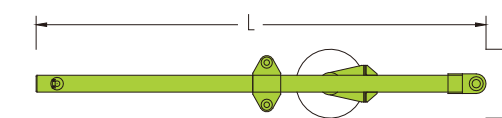

FA-frame		1 piece*
Length (L)	3230 mm	
Width (W)	730 mm	
Height (H)	490 mm	
Weight	280 kg	

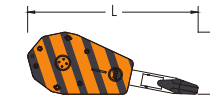

Load hook of 85t		1 piece*
Length (L)	1800 mm	
Width (W)	670 mm	
Height (H)	660 mm	
Weight	1195 kg	

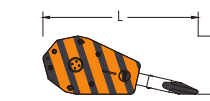

Load hook of 55t		1 piece*
Length (L)	1770 mm	
Width (W)	585 mm	
Height (H)	660 mm	
Weight	925 kg	



Load hook of 25t		1 piece*
Length (L)	1400 mm	
Width (W)	520 mm	
Height (H)	660 mm	
Weight	613 kg	

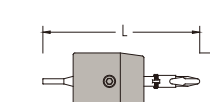

Load hook of 9t		1 piece*
Length (L)	955 mm	
Width (W)	350 mm	
Height (H)	350 mm	
Weight	265 kg	

### Notes:

1. Components are presented in diagrammatic drawings that are not drawn to scale. Length is a boundary dimension.
2. Weight of packaging is not counted in the weight above, which might be different from the actual weight due to manufacturing error.
3. There might be improvements made on components listed above, resulting modifications in dimensions and weight. Actual products to be delivered shall prevail.
4. Numbers of components marked \* are determined by the actual need.

## TECHNICAL DESCRIPTION



### Engine

Engine type---WEICHAI WP7G270E301  
 Rated power----199KW/2000rpm  
 Maximum output torque----1200N.m/(1200 - 1500)rpm  
 Fuel tank-----400L  
 Exhaust emission complies with China national 3 Emission Standards.

Optional:

Engine type---DONGFENG CUMMINS QSC8.3-C260  
 Rated power----194KW/2200rpm  
 Maximum output torque----1135N.m/(1300 - 1600)rpm  
 Fuel tank-----400L  
 Exhaust emission complies with China national 3 / EURO IIIA Emission Standards.



### Hydraulic system

Hydraulic pump: The main pump, a plunger pump, drives winches and the traveling mechanism. Dual gear pump is used for slewing and heat dissipation.

Control: pilot proportional control hydraulic system. The motor of hoisting winches is a variable plunger pump. Two cross-shaped hydraulic control levers and a dual foot-operated traveling control valve are used for controlling different executive components.

Hydraulic oil tank capacity-----520L



### Hoisting winch

Both the primary and the secondary hoisting winches are driven by an axial hydraulic variable-displacement piston motor through a built-in planetary reducer. Braking of the spring on winch motor is controlled by the balancing valve. The drum with a double-rope groove guarantees that rope of multiple layers will not intertwine together.

Main winch	Aux winch
Line pull-----Max.83.3KN	Line pull-----Max.83.3KN
Rope diameter-----24mm	Rope diameter-----24mm
Rope speed -----0-140m/min	Rope speed-----0-140m/min
Rope length-----230m	Rope length-----150m

Both hoisting winches with free-fall function is available for an option.



### Boom winch

The derricking winch is driven by an axial piston motor through a built-in planetary reducer and brakes through the spring on the motor end.

Cable drum lock: The winch is locked by ratchet wheel and ratchet pawl.

Line pull-----Max.71KN  
 Rope diameter-----20mm  
 Rope speed -----0-82m/min  
 Rope length-----150m



### Swing

The slewing gear is driven by an axial constant-displacement piston hydraulic motor through a planetary gear reducer. Small gear of the output shaft rotates around the slewing bearing ring fixed on the chassis so that the slewing table makes slewing movement of 360°. Lateral pulling force on boom can be effectively reduced through the function of free slewing.

Slewing bearing  
 Single-row-roller and four-point-contact slewing bearing, internal gearing  
 Slewing speed

The maximum slewing speed is 2.6 rpm.

## TECHNICAL DESCRIPTION



### Boom system

Main boom  
 Main boom length: 13m – 61m;  
 Consisting of 6.5m main boom pivot section, 6.5m main boom head, and main boom intermediate sections of 3m, 6m and 9m as well as tip boom.

Main boom length (m)	Main boom pivot section	Main boom head	3m main boom section	6m main boom section	9m main boom section
13	1	1	0	0	0
16	1	1	1	0	0
19	1	1	2	0	0
22	1	1	1	1	0
25	1	1	2	1	0
28	1	1	1	2	0
31	1	1	1	1	1
34	1	1	2	1	1
37	1	1	1	2	1
40	1	1	1	1	2
43	1	1	2	1	2
46	1	1	1	2	2
49	1	1	1	1	3
52	1	1	2	1	3
55	1	1	1	2	3
58	1	1	1	1	4
61	1	1	2	1	4



### Fixed jib

Fixed jib length: 7m – 19m; Consisting of 3.5m fixed jib pivot section, 3.5m fixed jib head and 4m fixed jib intermediate sections.

Fixed jib length (m)	Fixed jib pivot section	Fixed jib head	4m fixed jib section
7	1	1	0
11	1	1	1
15	1	1	2
19	1	1	3

# LIFTING PERFORMANCE

Main boom configuration

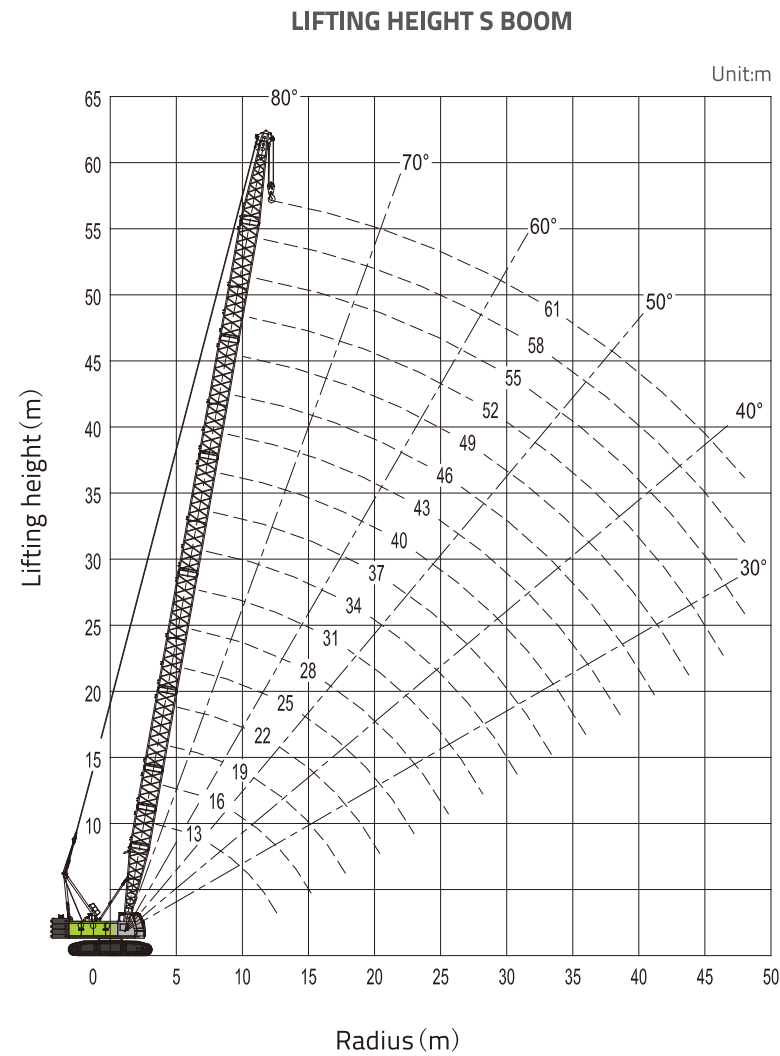

MAIN BOOM RATED LOADS																			
28500kg CWT																			
360° UNIT:T																			
MAIN BOOM LENGTH (M)																			
Radius (m)	13	16	19	22	25	28	31	34	37	40	43	46	49	52	55	58	61		
4.2	85																		
5	69.7	68.5	67																
6	55.5	55.5	55.5	54.3	52.5														
7	44.2	44.2	44.2	44.2	43.1	42.6													
8	36.5	36.5	36.5	36.5	36.5	36.1	35.4	34.3											
9	30.7	30.7	30.7	30.7	30.7	30.7	30.2	29.5	29.5	28.8									
10	26.6	26.6	26.6	26.6	26.6	26.6	26.3	25.9	25.9	25.2	24.8	24.4							
11	23.7	23.7	23.4	23.4	23	23	22.6	23	22.6	21.9	21.6	20.5	18.9						
12	21.2	20.8	20.8	20.8	20.8	20.5	20.5	20.5	20.1	19.6	19.6	18.9	18.5	18.2	15.6				
14		17.1	17.1	16.9	16.9	16.9	16.7	16.4	16.4	16.4	16	15.8	15.3	15.2	14	13.1			
16			14.2	14.2	14.2	14.2	13.9	13.9	13.9	13.8	13.5	13.5	13.4	13.1	12.8	12.4	11.8		
18				12.1	12.1	12.1	12	12	11.7	11.7	11.5	11.5	11.3	11.3	11	10.6	10.4		
20				10.6	10.6	10.6	10.4	10.3	10.2	10.2	9.9	9.9	9.7	9.7	9.5	9.2	9		
22				9.4	9.2	9.2	9	8.9	8.8	8.8	8.6	8.6	8.4	8.4	8.1	7.9			
24					8.3	8.1	8.1	7.9	7.8	7.7	7.7	7.5	7.4	7.2	7.2	7			
26						7.2	7.2	7	7	6.8	6.8	6.5	6.5	6.4	6.3	6.1			
28							6.5	6.4	6.3	6.3	6.1	6	5.9	5.9	5.7	5.6	5.4		
30								5.9	5.7	5.6	5.4	5.4	5.3	5.2	5	5	4.9		
32									5.2	5	5	4.9	4.7	4.6	4.5	4.5	4.3		
34										4.6	4.5	4.3	4.3	4.2	4	3.9	3.9		
36										4.2	4	4	3.9	3.8	3.6	3.5	3.4		
38											3.7	3.6	3.5	3.4	3.3	3.2	3.1		
40												3.3	3.2	3.1	2.9	2.8	2.7		
42													2.9	2.8	2.7	2.5	2.4		
44														2.5	2.4	2.2	2.2		
46															2.2	2.1	1.9		
48																1.9	1.8		
50																	1.5		
52																		1.3	
54																			1.1

# LIFTING PERFORMANCE

Main boom with fixed jib configuration

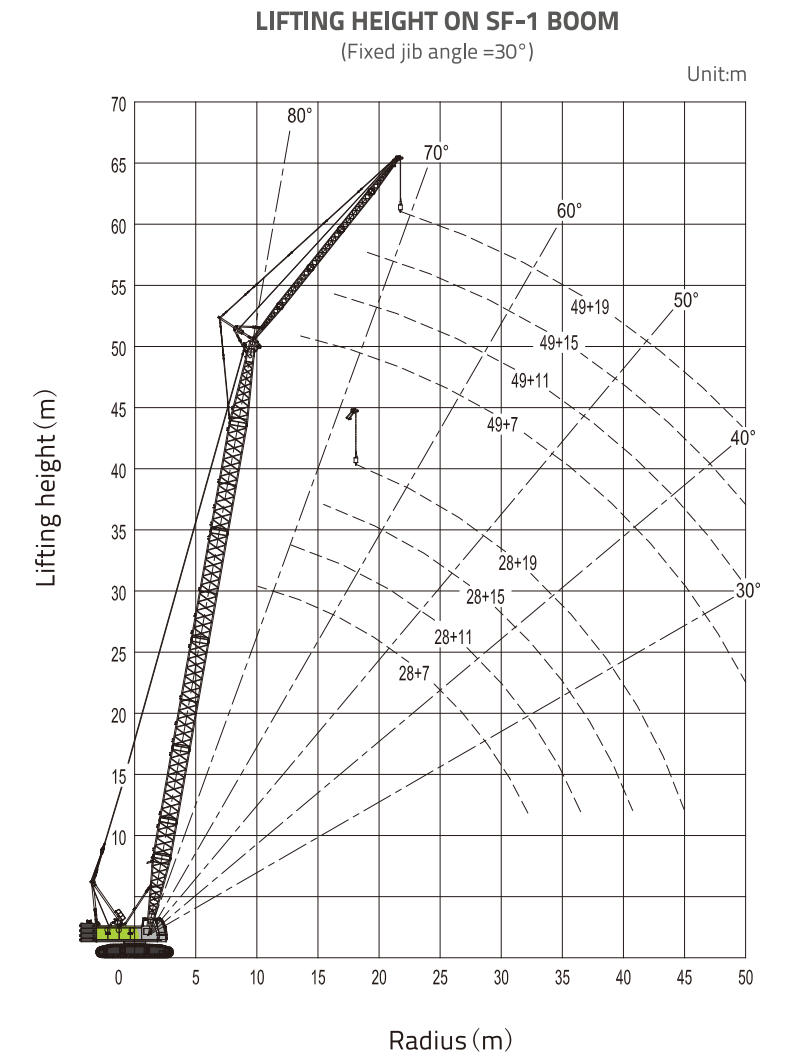
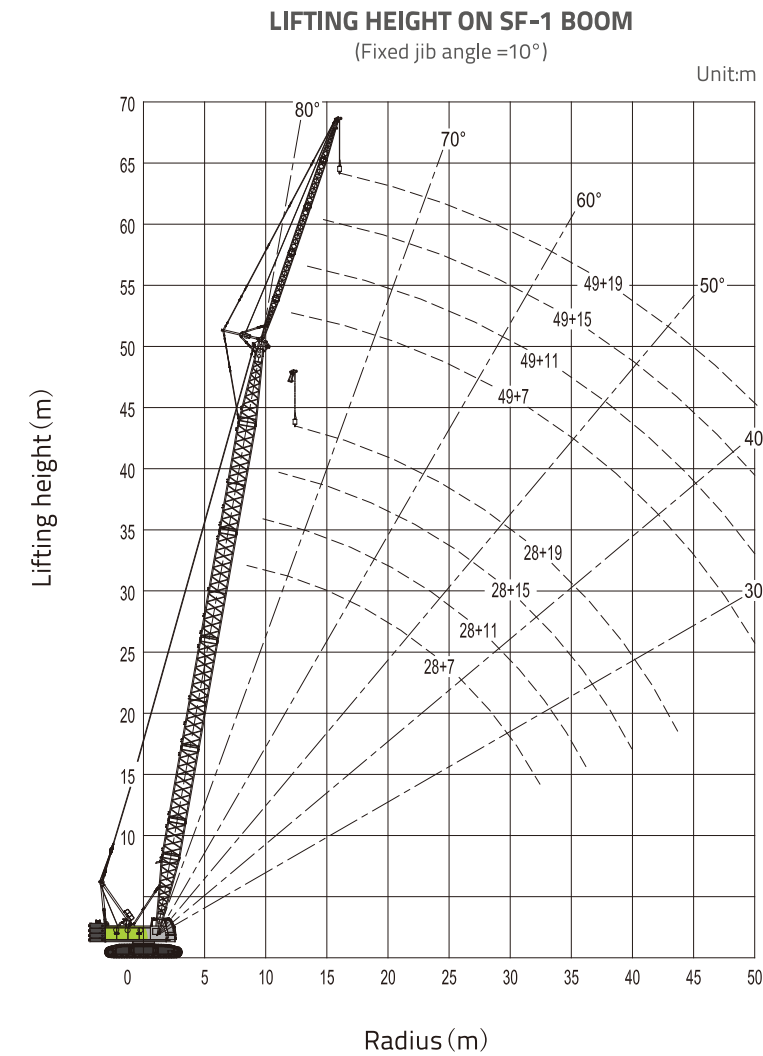

## LIFTING CAPACITY

Lifting capacity SF-1 boom (1/4)																
28500kg CWT								360° UNIT:T								
Main boom length	28				31											
Jin length	7		11		15		19		7		11		15		19	
Angle	10°	30°	10°	30°	10°	30°	10°	30°	10°	30°	10°	30°	10°	30°	10°	30°
9	15															
10	15		13.7					15								
11	15	14.7	13.4					15		13.3						
12	15	14.2	13.1		8.5			15	14.5	13.1		8.5				
14	15	13.4	12.4	9.2	8.5		5.7		15	13.7	12.5	9.4	8.5		5.7	
16	14	12.7	12.4	8.7	8.4	6.7	5.5		13.6	12.9	12.3	8.9	8.3		5.5	
18	12	12	11.6	8.3	8	6.3	5.3		11.8	12	11.8	8.5	8.2	6.4	5.4	
20	10.3	10.4	10.4	7.8	7.7	6	5.1	4.5	10.1	10.4	10.3	8	7.7	6.1	5.2	4.5
22	9.1	9.1	9.1	7.5	7.6	5.7	4.9	4.4	8.8	9.1	9.1	7.7	7.7	5.8	5	4.5
24	7.9	8.1	8.1	7.2	7.2	5.5	4.8	4.3	7.9	7.9	7.9	7.4	7.4	5.6	4.9	4.4
26	7.1	7.1	7.3	7	7.1	5.3	4.7	4.2	6.9	7.1	7.1	7.1	7.2	5.4	4.8	4.3
28	6.4	6.4	6.4	6.6	6.6	5.1	4.5	4	6.2	6.2	6.4	6.6	6.4	5.2	4.6	4.1
30	5.7	5.7	5.9	5.9	5.9	4.9	4.5	3.9	5.6	5.7	5.7	5.9	5.7	5	4.5	4
32			5.3	5.4	5.4	4.7	4.4	3.7	5.1	5.1	5.2	5.2	5.2	4.9	4.4	3.8
34			4.8	4.9	4.9	4.6	4.3	3.6	4.6	4.6	4.7	4.8	4.8	4.7	4.4	3.7
36				4.5	4.5	4.2	3.5				4.3	4.4	4.4	4.5	4.3	3.6
38				4.1	4.2	4.1	3.4				3.9	4	4.1	4.1	3.5	
40						3.9	3.4					3.7	3.7	3.7	3.4	
42						3.5	3.3						3.3	3.3	3.4	
44														3.1	3.2	
46																2.9

Lifting capacity SF-1 boom (2/4)																
28500kg CWT								360° UNIT:T								
Main boom length	34				37											
Jin length	7		11		15		19		7		11		15		19	
Angle	10°	30°	10°	30°	10°	30°	10°	30°	10°	30°	10°	30°	10°	30°	10°	30°
10	15															
11	15		13.7					15								
12	15	14.7	13.4					15		13.8						
14	15	13.9	12.9		8.5		5.8	15	14.2	13.1		8.5				
16	13.6	13.2	12.8	9	8.5		5.6	13.6	13.5	12.8	9.2	8.5		5.7		
18	11.7	12	11.8	8.6	8.2	6.5	5.4	11.5	11.8	11.8	8.7	8.4	6.6	5.5		
20	10.1	10.3	10.1	8.2	8	6.2	5.3	4.5	10	10.1	10.1	8.4	8	6.3	5.3	4.6
22	8.8	9	9	7.9	7.7	6	5.1	4.5	8.8	8.8	8.8	8	7.9	6.1	5.2	4.5
24	7.8	7.9	7.9	7.6	7.5	5.7	5	4.4	7.6	7.8	7.8	7.7	7.7	5.8	5	4.4
26	6.9	6.9	6.9	7.3	7.1	5.5	4.8	4.3	6.8	6.9	6.9	7.1	6.9	5.6	4.9	4.3
28	6	6.2	6.2	6.4	6.4	5.3	4.7	4.2	6	6	6	6.4	6.2	5.4	4.8	4.3
30	5.4	5.6	5.6	5.7	5.7	5.1	4.6	4.1	5.4	5.4	5.5	5.7	5.6	5.2	4.7	4.2
32	4.9	5	5.1	5.2	5.2	5	4.5	3.9	4.9	4.9	4.9	5.1	5.1	5.1	4.6	4
34	4.5	4.5	4.6	4.7	4.7	4.8	4.4	3.8	4.4	4.4	4.5	4.6	4.6	4.7	4.5	3.9
36	4.1	4.1	4.2	4.3	4.3	4.4	4.3	3.7	4	4	4.1	4.2	4.2	4.3	4.3	3.8
38			3.7	3.9	3.9	4	3.9	3.6	3.5	3.5	3.7	3.7	3.7	3.9	3.9	3.7
40			3.5	3.5	3.5	3.7	3.5	3.5			3.3	3.3	3.3	3.5	3.5	3.6
42				3.2	3.3	3.2	3.4				3	3	3.1	3.2	3.1	3.3
44				2.9	3	3	3.1						2.8	2.9	2.9	3
46						2.7	2.8						2.6	2.6	2.6	2.7
48							2.6								2.4	2.5
50															2.2	2.3

## LIFTING CAPACITY

Lifting capacity SF-1 boom (3/4)																
28500kg CWT								360° UNIT:T								
Main boom length	40				43											
Jin length	7		11		15		19		7		11		15		19	
Angle	10°	30°	10°	30°	10°	30°	10°	30°	10°	30°	10°	30°	10°	30°	10°	30°
11	8.5															
12	8.5		8.5					8.5								
14	8.5	8.5	8.5		8.5			8.5	8.5	8.5		8.5				
16	8.5	8.5	8.5	8.5	8.5		5.7	8.5	8.5	8.5	8.5	8.5		5.7		
18	8.5	8.5	8.5	8.5	8.5	6.7	5.6	8.5	8.5	8.5	8.5	8.5		5.6		
20	8.5	8.5	8.5	8.5	8.3	6.4	5.4	8.5	8.5	8.5	8.5	8.1	6.5	5.4		
22	8.4	8.5	8.5	8.2	8	6.2	5.2	4.5	8.4	8.5	8.4	8.4	8	6.3	5.3	4.5
24	7.4	7.6	7.6	7.9	7.6	5.9	5.1	4.5	7.4	7.6	7.6	7.9	7.6	6	5.2	4.5
26	6.6	6.8	6.8	7.1	6.9	5.7	5	4.4	6.6	6.8	6.6	6.9	6.8	5.8	5	4.4
28	5.9	6	6	6.2	6	5.5	4.9	4.3	5.7	5.9	5.9	6.2	6	5.6	4.9	4.4
30	5.2	5.4	5.4	5.6	5.4	5.4	4.8	4.2	5.2	5.2	5.2	5.5	5.4	5.4	4.8	4.3
32	4.7	4.8	4.9	5	4.9	5.2	4.6	4.1	4.6	4.7	4.7	4.9	4.8	5.1	4.7	4.2
34	4.3	4.4	4.4	4.5	4.4	4.7	4.6	4	4.1	4.3	4.3	4.4	4.4	4.6	4.4	4
36	3.9	3.9	3.9	4.1	4.1	4.3	4.1	3.9	3.7	3.7	3.9	4	3.9	4.2	4	3.9
38	3.5	3.5	3.5	3.7	3.7	3.9	3.7	3.8	3.3	3.3	3.5	3.5	3.5	3.7	3.5	3.8
40	3.1	3.1	3.2	3.3	3.3	3.5	3.3	3.5	3	3	3.1	3.2	3.2	3.3	3.2	3.5
42		2.8	2.9	3	3	3.1	3	3.2	2.7	2.7	2.8	2.9	2.9	3	2.9	3.1
44			2.6	2.7	2.7	2.8	2.8	2.9	2.4	2.4	2.5	2.6	2.6	2.7	2.6	2.8
46				2.4	2.5	2.5	2.5	2.6			2.3	2.3	2.3	2.5	2.4	2.6
48					2.2	2.3	2.3	2.4			2.1	2.1	2.1	2.2	2.2	2.3
50					2.1	2.1	2.2					1.9	2	1.9	2.1	
52						1.9	1.9						1.7	1.7	1.9	
54														1.5	1.7	
56															1.5	

Lifting capacity SF-1 boom (4/4)																
28500kg CWT								360° UNIT:T								
Main boom length	46				49											
Jin length	7		11		15		19		7		11		15		19	
Angle	10°	30°	10°	30°	10°	30°	10°	30°	10°	30°	10°	30°	10°	30°	10°	30°
12	8.5															
14	8.5	8.5	8.5					8.5		8.5						
16	8.5	8.5	8.5		8.5		5.8	8.5	8.5	8.5		8.5	8.5	8.5	8.5	
18	8.5	8.5	8.5	8.5	8.5		5.6	8.5	8.5	8.5	8.5	8.5	8.5	8.5	8.5	5.7
20	8.5	8.5	8.5	8.5	8.3	6.6	5.5	8.5	8.5	8.5	8.5	8.5	8.5	8.5	6.6	5.5
22	8.2	8.4	8.2	8.5	8.2	6.3	5.4	4.6	7.9	8.2	8.1	8.4	8.1	6.4	5.4	4.6
24	7.3	7.4	7.4	7.6	7.4	6.1	5.2	4.5	7.1	7.3	7.1	7.4	7.1	6.2	5.3	4.5
26	6.4	6.6	6.6	6.9	6.6	5.9	5.1	4.4	6.2	6.6	6.2	6.6	6.4	6	5.2	4.5
28	5.7	5.9	5.7	6	5.9	5.7	5	4.4	5.6	5.7	5.7	5.9	5.7	5.8	5	4.4
30	5.1	5.2	5.2	5.4	5.2	5.5	4.9	4.3	4.9	5.1	5.1	5.3	5.1	5.4	5	4.3
32	4.5	4.6	4.6	4.9	4.7	5.1	4.8	4.2	4.4	4.6	4.5	4.7	4.6	4.9	4.7	4.3
34	4.1	4.1	4.2	4.4	4.3	4.5	4.3	4.1	3.9	4.1	4.1	4.3	4.1	4.4	4.2	4.2
36	3.5	3.7	3.7	3.9	3.7	4.1	3.9	4	3.5	3.5	3.5	3.7	3.7	4	3.7	4.1
38	3.2	3.3	3.3	3.5	3.3	3.7	3.5	3.7	3.1	3.2	3.2	3.3	3.3	3.5	3.3	3.7
40	2.9	2.9	3	3.1	3	3.2	3.1	3.4	2.7	2.8	2.9	3	2.9	3.2	3	3.3
42	2.6	2.6	2.7	2.8	2.7	2.9	2.8	3	2.5	2.5	2.5	2.7	2.6	2.8	2.7	3
44	2.3	2.4	2.4	2.5	2.5	2.6	2.5	2.8	2.2	2.2	2.3	2.4	2.4	2.5	2.4	2.7
46	2.1	2.1	2.2	2.2	2.2	2.4	2.3	2.5	1.9	2	2.1	2.1	2.1	2.3	2.2	2.4
48			1.9	2	2	2.1	2.1	2.2	1.7	1.7	1.8	1.9	1.9	2	1.9	2.1
50				1.7	1.7	1.8	1.9	1.9	2		1.5	1.5	1.7	1.7	1.8	1.9
52																